

Best Practice for *Architectural Concrete*



Contents

1 Introduction	5	3 Architectural concrete – call for tenders, award of contract and realization	20
2 Basic conditions for the planning and execution of architectural concrete components	6	3.1 List of tasks in the tender	20
2.1 The architectural concrete team	6	3.2 Analysis of the tender	22
2.2 Guidelines for architectural concrete	8	4 Architectural concrete – formwork (formwork systems)	26
2.3 Codes of conduct	12	4.1 Wall formwork	26
		4.2 Column formwork	42
		4.3 Slab formwork	47
		5 Formlining	50
		5.1 Preface	50
		5.2 Characteristics of the formlining surface	51
		5.3 Using timber for formlining	56
		5.4 Formlining sheets	62
		6 Constructive details in architectural formwork construction	72
		6.1 Fixing materials	72
		6.2 Sealing the formwork	74
		6.3 Tie points for architectural concrete	76
		6.4 Structural design of formlining joints in architectural concrete	79
		6.5 Formed concrete edges	83
		6.6 Formed internal corners	85

Edition 04/2018

Publisher

PERI GmbH
Formwork Scaffolding Engineering
Rudolf-Diesel-Straße 19
89264 Weißenhorn
Germany
info@peri.de
www.peri.com

7 Release agents	86	9 Easy compacting concrete (ECC) + self-compacting concrete (SCC) and architectural concrete	96
7.1 General requirements for release agents in guidelines and data sheets	86	9.1 General	96
7.2 Requirements for the release agents	87	9.2 Fresh concrete pressure	98
7.3 Effectiveness of the release agent	88	9.3 Special requirements of self-compacting concrete on the formwork	99
7.4 Selection of a suitable release agent	89		
7.5 General instructions for the use of release agents	90	10 Assessment, acceptance, defects	100
		10.1 Assessment and acceptance	100
8 Ability for concreting and concrete placement	92	10.2 Defects	101
8.1 Ability for concreting of the concrete components	92	10.3 Presentation of some typical defects	102
8.2 Concrete placement and compaction	94	11 Architectural concrete working instructions for the construction site	106

Important notes

All current safety regulations and guidelines applicable in those countries where our products are used must be observed.

The photos shown in this brochure feature construction sites in progress. For this reason, safety and anchor details in particular cannot always be considered conclusive or final. These are subject to the risk assessment carried out by the contractor.

In addition, computer graphics are used which are to be regarded as system representations. For ensuring a better understanding, these and the detailed illustrations shown have been

partially reduced to certain aspects. The safety installations which have possibly not been shown in these detailed descriptions must nevertheless be available. The systems or items shown might not be available in every country.

Safety instructions and load specifications are to be strictly observed at all times. Separate structural calculations are required for any deviations from the standard design data.

The information contained herein is subject to technical changes in the interests of progress. Errors and typographical mistakes reserved.



1 Introduction

Definition of "Architectural Concrete"



Architectural concrete has become increasingly more important in recent years. Today, visible concrete surfaces are in great demand both as a stylistic means as well as a design form of modern architecture.

The aim of this Best Practice to Architectural Concrete is to present the complexity of architectural concrete itself. Thereby, the focus is on the

formwork sector; in addition, influencing factors such as concrete and release agents as well as contractual points are explained.

This Best Practice to Architectural Concrete primarily serves as a guide to support building contractors evaluate the tender, select the formwork as well as other detailed solutions that contribute towards achieving the contractual target.

With visible concrete surfaces, for which a clear and practical-oriented executable description is provided, one speaks of concrete surfaces with special requirements placed on the surface appearance. The DBV Code of Practice "Architectural Concrete" presents the current state of technology and gives specific instructions for practical implementation.

DBV Code of Practice "Architectural Concrete" (Edition 06/2015)

The architectural concrete surface is the area of concrete that remains unconcealed after completion that shows the characteristics of the design and manufacture (e.g. form, texture, colour, formlining, joints) and which plays a decisive role in determining the architectural impression of a structural component or structure. A wide range of architectural concrete surfaces can be achieved through the use of special formwork and specific concrete composition among other things.

Architectural concrete surfaces must be adequately described in the performance specifications, i.e. clearly and achievable. Using only the requirement according to "architectural concrete" as a collective term or as an alternative for a clear description of the visible surface is insufficient.

In order to realise an architectural concrete surface, the following questions have to be clarified:

- Which quality features should the architectural concrete surface exhibit?
- Which requirements are to be specified in the tender documents?
- Which requirements are placed on the formwork in order to form the concrete surface?
- Which requirements are placed on the concrete formulation, manufacture and placing of the concrete?

For architectural concrete surfaces, the following design possibilities are available:

- Formwork impressions (formlining)
- Surface structure of the formlining
- Fixing of the formlining
- Pattern of panel and formlining joints
- Arrangement and design of tie points
- Special concrete formulations
- Choice of cement, aggregate granulation and colour, concrete additives and more.
- Surface coating through covering paint or a translucent colour on the concrete surface
- Colour additives in the concrete result in integrally-coloured concrete

Subsequent surface treatment through:

- washing
- cleaving
- pointing
- granulating
- chiselling
- sandblasting
- acid washing
- sanding
- polishing
- flame-cleaning
- rolling
- smoothing
- brooming

2 Basic conditions for the planning and execution of architectural concrete components

2.1 The architectural concrete team

For a structure/structural component with particular concrete surface requirements, coordinated co-operation of everyone involved in the planning and execution is essential.

The expectations and requirements of the planners and client must correspond to that which can be realized in the actual execution. In addition to the contractual and legal framework, the planner is well advised to co-ordinate his expectations with the specialists in the architectural concrete team.

As a general rule, the contract is not allocated in the planning phase which means that no final decision has been taken regarding who will carry out the work. It is possible that, for example, a consultation agreement can be concluded with a competent specialist company such as a formwork or form-lining manufacturer.

A consultancy contract can be signed with an engineering office experienced in the execution of architectural concrete structural components. This engineering office will then assume the role of architectural concrete coordinator in the architectural concrete team – see diagram below. The partners should work together in an architectural concrete team.

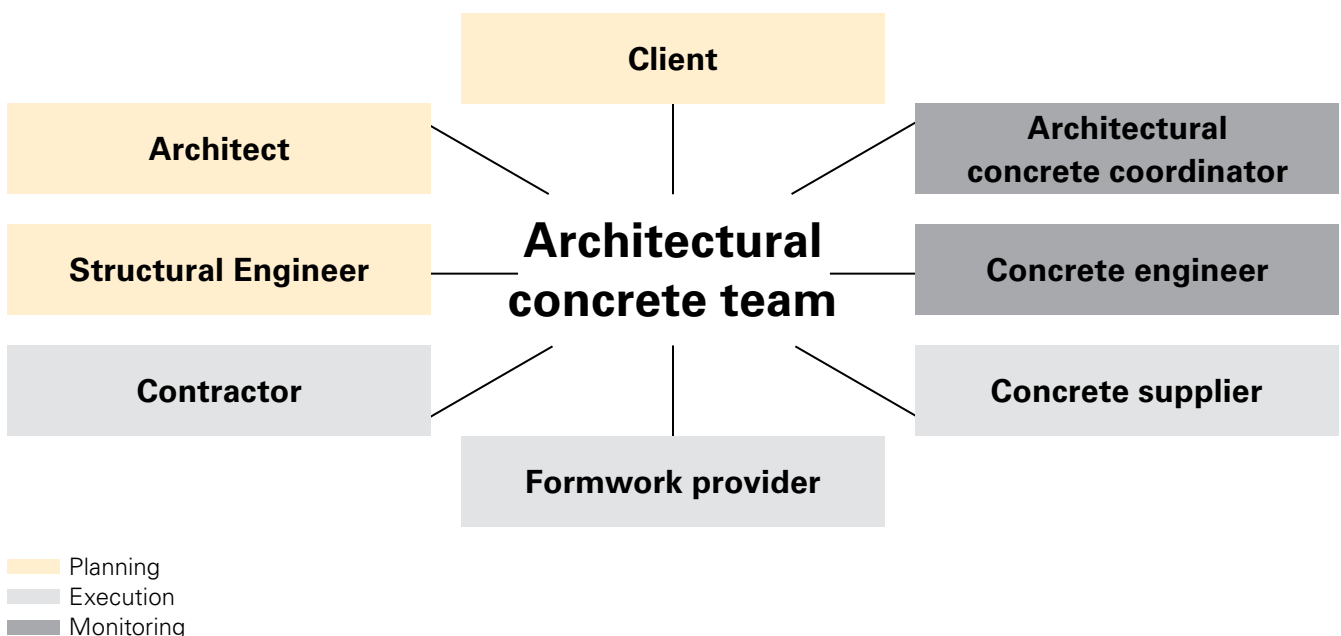

Planning

Client

Expresses his wishes for the structure/ structural component as well as providing the financial framework.

Architect

Creates the design for the structure/ structural component based on these wishes and defines the concrete surface requirements.

Structural Engineer

Calculates the executable, load-bearing construction and creates the implementation plans; with SB 3 and SB 4 concrete, the forming plans should ideally include all information necessary to create the cubic volume in the building shell. These are: construction joints, tie arrangement, formlining joints, mounting parts and recesses of any size (including light switches, sockets, etc.) for walls and slabs.

Execution

Contractor

Has the task of constructing the building according to the client's wishes in accordance with the design, construction and the agreed price.

He works together, among others, with the following cooperation partners:

Formwork provider

Plans the formwork required according to the project specifications with:

- Selection of the formwork system as well as the type of formlining
- Joint pattern and joint configuration unless specified by the planner
- Tie pattern and tie configuration unless specified by the planner

Supplies the formwork in accordance with the agreed delivery conditions.

Concrete supplier

Delivers the concrete which has the required properties for the described structure/structural component.

Monitoring

Concrete engineer

- Has extensive knowledge of concrete regarding composition, production, processing and testing
- Ensures and supervises that the materials for the concrete are suitable and that these can be technically implemented, as well as selecting an appropriate type of concrete
- Ensures and supervises the careful placing of the concrete, together with adequate and suitable protection, until it has sufficiently hardened (curing)

Architectural concrete coordinator

- Leads the architectural concrete team and coordinates the work carried out by the partners
- Accompanies and checks all planning and construction stages which includes, among other things, lack of information and missing details in the planning and specifications
- Determines the most suitable formwork and formlining together with the contractor / formwork provider
- Inspects the structural component, and that the reinforcement can be concreted

The role of the architectural concrete coordinator can be sensibly combined with that of the concrete engineer and taken on by an experienced engineering office. The client should therefore assign such a task to this office. Unfortunately, the reality is that a coordinator is not available for most architectural concrete projects which means that there is virtually no expert liaison between planning and execution. As a consequence, this gives rise to well-known problems and differences between the views and expectations of the contractor/architect and those of the construction company particularly with regard to the quality and costs.

2 Basic conditions for the planning and execution of architectural concrete components

2.2 Architectural concrete guidelines

DIN no.	Title
DIN 1045-3 Amendment 1:2013-07 Issue date 2013-07	Load-bearing structures made of concrete, reinforced concrete and pre-stressed concrete – Part 3: Construction work – Application rules for DIN EN 13670, Amendment to DIN 1045-3:2012-03
VOB (German Construction Contract Procedures) Part C DIN 18299:2016-09	ATV Concrete Work, 0.2 Execution Details
DIN 18218:2010-01 Issue date 2010-01	Pressure of fresh concrete on vertical formwork
DIN 18202:2013-04 Issue date 2013-04	Tolerances in Building Construction
DIN 68791:2016-08 Issue date 2016-08	Large-area formlining sheets made of block plywood for concrete and reinforced concrete
DIN 68792:2016-08 Issue date 2016-08	Large-area formlining sheets made of laminated veneer plywood for concrete and reinforced concrete
DIN 4235-1:1978-12 Part 2 and Part 4 Issue date 1978-12	Compacting concrete with vibrators <ul style="list-style-type: none"> ■ Compacting with immersion vibrators ■ Compacting in situ concrete with formwork vibrators
DIN EN 12812:2008-12 Issue date 2008-12 Shoring – requirements, dimensioning and design DIN EN 12812 Application Guidelines:2009-08 Application guidelines for shoring according to DIN EN 12812 Issue date 2009-08	Shoring – requirements, dimensioning and design Application guidelines for shoring according to DIN EN 12812

VOB (German Construction Contract Procedures) Part C DIN 18331, ATV Concrete Work

Section 0.2

Information on the execution.

Section 0.2.4

For visible concrete surfaces, among other things:

- classification of the visible surfaces,
- surface texture, description of the formwork and formlining systems if necessary, surface design of non-formed areas,
- colour shade,
- surface structure,
- formation of joints, edges, ties and tie holes as well as formwork joints,
- number of test surfaces, selection of the reference surface

requirements for the execution of formwork joints as well as construction and dummy joints and their arrangement with visibly remaining concrete surfaces.

Section 0.3

Individual details when deviating from ATV.

- If a specific type or design for the formwork has been agreed on, or if certain requirements are placed on the concrete surfaces, e.g. chamfered edges, nib removal ...

Section 3.4

Concrete with designed visible concrete surfaces.

Concrete with particular requirements on the surface appearance specified in the project description.

Section 4.2.1

Scope of the constructional documentation (1).

The constructional documentation includes the drawings required for the

execution of the structure, static calculations and, if necessary for the construction work, a supplementary project description as well as any general building inspectorate approvals and test certificates.

Section 4.2.4

Building specifications.

(1) Information which is required for the execution of the building work, verification of the drawings or static calculations, but which cannot easily be inferred from the documentation in accordance with 4.2.2 and 4.2.3, must be included in a building specification and described accordingly. This also includes the required information for concrete with designed visible concrete surfaces.

Definitions according to current state-of-the-art technology

Concrete surfaces

Concrete surfaces are the mirror image of the formlining or the result of subsequent processing and/or treatment. The formwork sheeting must be selected according to the requirements of the concrete surfaces.

Concrete surfaces without special requirements

The method of manufacture and the formwork for these surfaces is decided by the contractor. Surface processing and treatment is not required, repairs are permitted.

Concrete surfaces with requirements regarding the appearance

These are visibly remaining concrete surfaces, for which a clear and practically executable description must be available. A comparison with buildings already completed can therefore be an effective help. The work is to be described clearly and in sufficient detail so that all tenderers can understand

the description in the same way and are able to calculate their prices with great certainty and without extensive preparatory work. If a comparison is made with sample pieces or existing structures, it must be taken into account that the required surface areas will only be the same under corresponding conditions (dimensions, basic materials, concrete mix, formwork, processing, subsequent curing, weather, age of concrete, etc.). Appropriate information is required as far as the arrangement and formation of the joints along with tie points have an influence on the concrete surfaces. Professional repair work with suitable materials is permitted.

Concrete surfaces designed with formlining

Different design possibilities are available through the use of appropriate formlining. The concrete surface structures are to be named in the tender documentation.

Treated concrete surfaces

These are concrete surfaces and non-formed areas which are to be given additional treatment. The types of treatment are, for example, washing, cleaving, pointing, chiselling, sand-blasting, acid washing, sanding, flame-cleaning, rolling, smoothening, brooming.

Subsequently treated concrete surfaces

These are concrete surfaces that are treated additionally for special requirements, e.g. through fluation, polishing, sealing, coating.

Concrete surfaces with technical requirements

The surfaces have certain technical functions to fulfil and/or serve subsequent work operations. Each of the requirements to be met is clearly formulated in the specifications. Professional repair work with suitable materials is permitted.

2 Basic conditions for the planning and execution of architectural concrete components

2.2 Architectural concrete guidelines

DIN 18202:2013-04 Issue date 2013-04

In DIN 18202, the deflection tolerances are determined in Table 3 and Fig. 6.

Position deviations are defined as threshold values dependent on the measuring distances.

For the formwork construction, and thus the formed concrete surfaces, Lines 5 to 7 are binding.

from DIN 18202 , Table 3 – Limit values for deflection deviations

Col-umn	1	2	3	4	5	6
Line	Reference	Position deviations (limit values), in mm, for distance of measuring points in m, up to				
		0.1	1 ¹⁾	4 ¹⁾	10 ¹⁾	15 ¹⁾
5	Wall surfaces and soffits of structural slabs that are unfinished	5	10	15	25	30
6	Wall surfaces and soffits of slabs that are finished, e.g. plastered walls, wall claddings, suspended ceilings	3	5	10	20	25
7	As in line 6, but with more stringent specifications	2	3	8	15	20

¹⁾ Intermediate values are to be taken from figures 5 and 6 of DIN 18202 and round up to full mm.

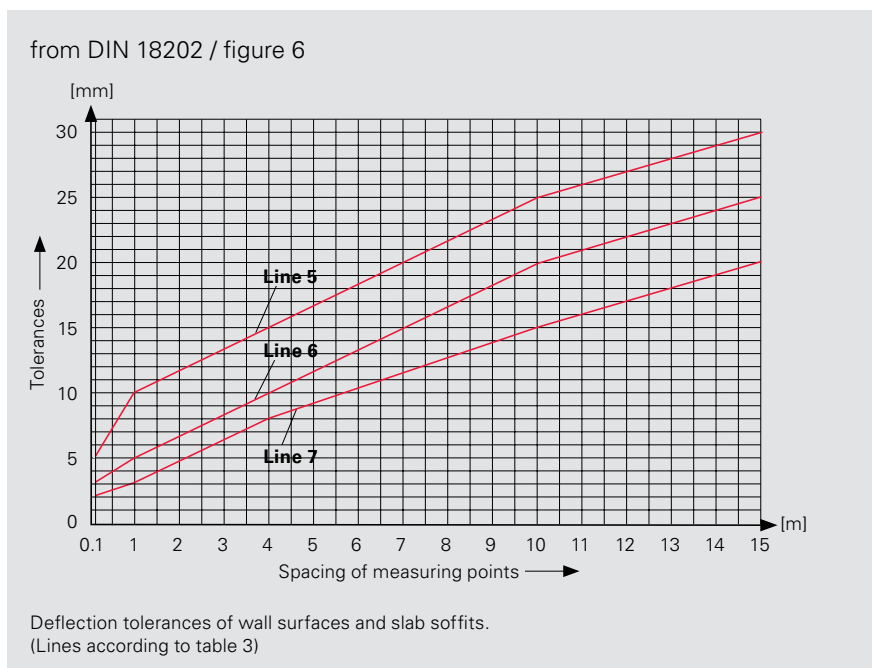

Information on the tolerances

Tolerances for concrete surfaces accumulate e.g. for a wall resulting from the proportion of formlining, formwork system, tie system, measuring tolerances, deflections and expansion from the load.

In table 3 and fig. 5, the lowest measuring distance is 0.1 m. This means that no statement can be made regarding the projections and off-sets within the area of the formlining and element joints. In the DBV Code of Practice "Architectural Concrete", tolerances have been determined for texture/formwork unit joints and formlining joints criteria concerning projections and off-sets in these areas.

DIN standards for formlining sheets

DIN 68791:2016-08, see page 8

In this standard, the quality parameters of the sheeting, among other things, are determined. For architectural concrete, the statements about permissible dimensional deviations are of particular importance.

With plywood sheets, this amounts to, for example, ± 3.0 mm in length and width, $+0.2 / -0.9$ mm in the thickness whereby these values apply at the time of delivery from the manufacturer.

Through the swelling of the sheets due to the processing moisture during use on the construction site, these values could increase even more.

These permissible dimensional deviations are to be taken into consideration for the joint configuration of the formlining.

2 Basic conditions for the planning and execution of architectural concrete components

2.3 Codes of Practice

Contractual incorporation of codes of practice:

As codes of practice are not included in recognized engineering rules this means when incorporating such codes of practice in construction contracts, a comprehensible description must be featured in the tender documentation for the bidder showing which code of practice requirements have been addressed in the preliminary remarks as well as the items. A general reference to codes of practice is insufficient.

DBV Codes of Practice (German Society for Concrete and Construction Technology) which should be taken into consideration for architectural concrete:

- Architectural Concrete (Version 06/2015)
- Concrete Formwork and Striking Times (Version 06/2013)
- Release Agents for Concrete, Part A and B (Version 03/1997 and 08/1999) (deleted entirely)
- Ability to concrete structures made of concrete and reinforced concrete (Version 01/2014)

2.3.1 DBV Code of Practice – "Architectural Concrete"

The DBV/BDZ Code of Practice, "Architectural Concrete", provides a good basis for the planning, awarding of contract, execution and processing of architectural concrete surfaces.

In Table 1 of the DBV Code of Practice, "Architectural Concrete", an overview of the architectural concrete classes and relevant requirement criteria is given. The requirement criteria are defined in various other tables in the Code of Practice.

In the Code of Practice, 4 architectural concrete classes are defined:

AC 1

- Concrete surfaces with low design requirements e.g. basement walls or areas having a predominantly commercial use

AC 2

- Concrete surfaces with standard design requirements (e.g. staircase areas, retaining walls)

AC 3

- Concrete surfaces with high design requirements (e.g. Façades in building construction)

AC 4

- Concrete surfaces with particularly high design requirements (e.g.: prestigious structural components in building construction)

			1	2	3	4	5	6	7	8	9			
Architectural concrete class			Examples	Requirements for formed architectural concrete according to class regarding					Additional requirements		Production categories			
				Texture	Porosity ¹		Colour consistency ^{1,2}		Evenness	Construction joints and formwork joints		Tests ³	Form-lining sheet ⁴	
					s	na	s	na						
1	Architectural concrete with	low requirements	SB1	Concrete surfaces with low design requirements (e.g.: basement walls or areas having a predominantly commercial use)	T1	P1		FT1	E1	AF1	ex-empted	FC 1	low	
		standard requirements	SB2	Concrete surfaces with standard design requirements (e.g.: staircase areas, retaining walls)	T2	P2	P1	FT2	FT2	E1	AF2	recommended	FC 2	medium
		special requirements	SB3	Concrete surfaces with high design requirements, e.g. façades	T3	P3	P2	FT2	FT2	E2	AF3	urgent recommended	FC 2	high
			SB4	Concrete surfaces with particularly high design requirements, e.g. representative building components	T3	P4	P3	FT3	FT2	E3	AF4	required	FC 3	very high

¹ a = absorbent or na = non-absorbent formlining; see table 4

² The overall appearance of an architectural concrete surface can normally only be assessed after a longer period of time (i.e. after several weeks). Colour consistency is assessed using the normal viewing distance – in accordance with Section 7.

³ Requirements for tests, see also table A.6

⁴ Requirements for formlining sheets, see table 3

Information on all architectural concrete and requirement classes:

For the purposes of this Code of Practice, the overall appearance of an architectural concrete surface is the basic evaluation criterion for the agreed class of architectural concrete.

The design effect of the architectural concrete surface can basically only be adequately assessed through its overall effect, i.e. not according to comprehensively explained individual characteristics. The absence of contractually agreed individual items should only then lead to rectification obligations if the design effect of the overall appearance of the component in question has been negatively affected.

In the assessment, it should also be noted that every component is to be considered unique as well as taking into account Sections 5.1.2 and 7 of this Code of Practice.

Minor irregularities, e.g. texture and colour shade are characteristic in all classes of architectural concrete.

Table 1, Code of Conduct "Architectural Concrete": architectural concrete classes and relevant requirement classifications

2 Basic conditions for the planning and execution of architectural concrete components

2.3 Codes of Practice

Formwork-related explanations regarding the criteria: texture, formwork element joints

T1

- In the formwork element joints, leaking grout/fine mortar up to 20 mm wide and approx. 10 mm deep is permissible.
- Frame impression of the formwork element permissible.



Element joint impression of panel formwork



Element joint impression of girder formwork

For this requirement, all system formwork which corresponds to the GSV (German Quality Protection Association for Concrete Formwork) "Quality Criteria for Rental Formwork Guideline" is applicable if used correctly. Additional sealing of the formwork element joints is not necessary. The formwork class is to be assessed separately (see DBV Code of Practice, Table 3).

T2

- In the formwork element joints, leaking grout/fine mortar up to 10 mm wide and approx. 5 mm deep is permissible:
- Element joint off-set up to approx. 5 mm permissible.
- Height of remaining nibs up to approx. 5 mm permissible.
- Frame impression of the formwork element permissible.



Element joint impression of panel formwork



Element joint impression of girder formwork with boards as formlining

For this requirement, all system formwork which corresponds to the GSV (German Quality Protection Association for Concrete Formwork) "Quality Criteria for Rental Formwork Guideline" is applicable if used correctly. Particular attention must be paid to ensuring a correct element joint in the joints. Additional sealing is not normally necessary. The concrete must possess good water retaining characteristics and is not prone to bleeding. The formwork class is to be assessed separately.

T3

- Smooth, closed and, to a large extent, uniform concrete surface.
- In the formwork element joints, leaking grout/fine mortar up to 3 mm wide permissible.
- Fine, technically unavoidable nibs up to approx. 3 mm permissible.
- Other requirements (e.g. tie arrangement, formlining joints, cone seals) are to be specified in detail.



Girder formwork with individual boards

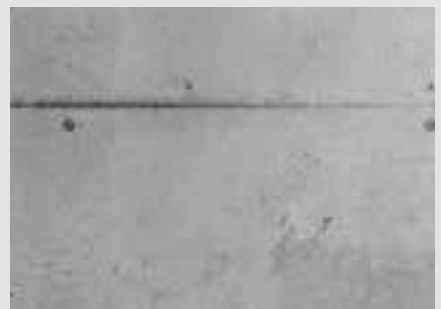

Girder formwork with film-coated plywood panels

The use of panel formwork is only possible if having a frame impression on the concrete surface has been expressly allowed. With girder formwork, the formlining sheets are pushed directly together. Additional sealing in the element joints using sealing strip or similar material is strongly recommended for T3 but this is dependent, however, on the accuracy of the formlining edges. This work is an additional service and must be agreed upon accordingly together with appropriate compensation. The concrete must possess good water retaining characteristics and is not prone to bleeding. The formlining class is to be assessed separately.

Colour uniformity

If the quality of the formlining is of a good standard, the influence on the colour consistency of the concrete surface is only minimal.

The absorbency of the formlining does have an influence. As the degree of absorbency increases, the colour of the concrete becomes darker. With wood surfaces without any coating, the grain begins to appear due to the different absorbent qualities of early wood and late wood, as well as of cross-grained wood (branches). Sheets with a phenol resin film have very weak absorption characteristics. However, as the number of uses increases, there is a corresponding change in the absorp-

tion characteristics so that the concrete surface turns increasingly darker. All-plastic sheets or those with a polypropylene coating do not have any absorption characteristics. As a result, no colour change to the concrete surface – caused by the formlining – occurs with these materials during increased use.

The roughness of the formlining influences the flow behaviour of the ultra-fine concrete particles and water on the formlining surface. Smooth surfaces favour the formation of water streaking effects on the concrete surface. If necessary, the concrete composition is to be changed here.

Impurities on the formlining surface can become more firmly fixed due to an adhesive-type release agent, or excessive use of an agent, and lead to a discolouration of the concrete surface.

With increasing requirements on the concrete surface, the formlining is therefore to be carefully cleaned and protected up to the time of concrete placement.

Influence of the release agent: the effects of the release agent on the colour consistency of the concrete surface, see Section 7, "Release Agents".

Evenness

The evenness requirements according to DIN 18202:2013-04, Table 3, Lines 5 and 6, are achievable without any extra effort through appropriate use of formworking materials and maintaining the predetermined fresh concrete pressure.

Higher evenness requirements are to be agreed upon separately. All work required for this is to be specified in detail by the client.

Note:

Higher evenness requirements, e.g. line 7, cannot be technically carried out in an effective manner.

In individual cases, measures are to be determined depending on the selected formwork and formlining systems, as well as the possible tolerances, e.g. for wall formwork

- due to swelling and shrinkage of the formlining,
- from the formwork system (production and assembly tolerances),
- from the tie system (tie expansion),
- from the measuring system,
- assembly tolerances on the construction site,

- reduction of the formlining stiffness due to an increase in the moisture content of the panel and other reasons

determining threshold values or additional measures.

Normally, special demands are placed on the offset at the formlining joint or formwork element joint. For the formlining tolerances, see page 28 Architectural concrete formwork.

2 Basic conditions for the planning and execution of architectural concrete components

2.3 Codes of Practice

Construction and formlining joints

AF 1

- Offset of areas between two concreting sections up to approx. 10 mm permissible.
- This requirement is achievable with all PERI system formwork if used correctly without any additional measures.

AF 2

- Offset of areas between two concreting sections up to approx. 10 mm permissible.
- Leakage of fine mortar onto the previous concreting section must be removed in good time. Trapezoidal strips or similar are recommended.

This requirement is achievable with all PERI system formwork if used correctly. Special attention is to be paid to the contact pressure of the formwork for the second concreting section (e.g. from formwork ties and props) on the first concreting section.

Additional sealing strips are not required. Using a trapezoidal strip in the first concreting section results in a sharp-edged, straight joint design.

AF 3

- Offset of areas between two concrete sections up to approx. 5 mm permissible.
- Leakage of fine mortar onto the previous concreting section must be removed in good time.
- Trapezoidal strips or similar are recommended.

This requirement is achievable with all PERI system formwork with careful planning and execution particularly for the second concreting section (props, tie arrangement and tensioning, limiting deflection). Additional sealing strips (e.g. sponge rubber) are recommended. Trapezoidal strips or similar as in AF 2.

AF 4

- Planning of the detailed execution is required.
- Offset of areas between two concrete sections up to approx. 5 mm permissible.
- Leakage of fine mortar onto the previous concreting section must be removed in good time.
- Other requirements (e.g. design of construction and formlining joints) are to be specified in detail.

On the basis of those requirements specified for the joint, detailed planning is to be provided depending on the selected formwork system and the formlining. In the process, the swelling and shrinking characteristics of the timber material (formlining) in particular are to be taken into consideration.

porosity

The porosity of the concrete surface depends on different factors. In Table 2 of the DBV Code of Practice, the number of pores has been evaluated on a test area measuring 0.50 x 0.50 m. In the process, pores $\varnothing < 2$ mm are not taken into account and pores $\varnothing > 15$ mm excluded.

Influences from the formlining on the porosity of the concrete surface:

Using vibrated concrete:

During concrete compaction on vertical or inclined surfaces, pores filled with water/air and fine particles move towards the formwork surface. On the concrete surface, the proportion of air and water pores increases. With non-absorbent formlining, no water is assimilated from the concrete and the pores are visible on the concrete surface. With an increased absorbency level of the formlining, water from the concrete surface is absorbed by the formlining itself. This means that the amount of water pores on the concrete surface is then reduced.

Roughness of the formlining and adhesiveness of the release agent

Using a smoother type of formlining and a lower level of release agent adhesiveness (very thin film of a quick-drying release agent), means the less the pores attach themselves to the formlining surface and rise more easily. In order to take advantage of this effect, small pouring layer heights (0.30 m to 0.50 m) are to be maintained when concreting and concrete compaction carried out according to DIN 4235-1:1978-12 Part 2 and Part 4, Issue Date 1978-12.

Easy compacting (F5 and F6) and self-compacting concrete (SCC)

Due to the absence of compacting energy through the vibrating process, pores as well as the finest grains do not move to the formwork surface. This means that the proportion of pores on the concrete surface is not increased.

The absorbency of the formlining has the same influence as with vibrated concrete. The influence exerted by the roughness the formlining as well as the adhesiveness of the release agent does not have any measurable significance.

Formlining classes

S	1	2	3	4
Z	Feature	Formlining class ¹		
		FC 1	FC 2	FC 3
1	Drill holes	close with plastic or wooden plugs, or using a suitable repair method	permitted as repair points ²	not permitted ³
2	Nail and screw holes	permitted	without chipping permitted	not permitted ³
3	Damage to the formlining due to internal vibrators	permitted	not permitted ³	not permitted
4	Scratches	permitted	in AC 2, minor scratches up to 1 mm deep permissible ⁶ , otherwise permitted as repair points ²	not permitted ³
5	Concrete or mortar surplus ⁷	no extensive build-up	not permitted	not permitted
6	Cement residue	permitted	permitted	not permitted ⁴
7	Swelling of the formlining in screw or nail areas, or corrugation on the edge surfaces ("rippling")	permitted	permitted in AC 2 not permitted in AC 3 ^{4, 5}	not permitted ⁵

¹ The formlining must be checked regarding its defined condition before every use.

² Repairs to the formlining must be carried out by qualified personnel in a proper and professional manner.

³ As repair points² permissible in consultation with the client.

⁴ Permitted after consultation with the client.

⁵ Material-related thickness tolerances in the edge area are to be tolerated.

⁶ See also GSV Information Booklet "Rental Formwork", Güteschutzverband Betonschalungen e.V., Ratingen [R17].

⁷ Concrete or mortar surplus in nail holes and between the formlining and element edge is permissible.

Experience shows that clients often allow greater tolerances regarding formlining features.

Insofar as Footnotes 3 and 4 of this table are used, consultation or agreement with the client is required.

This should take place by or at the tender stage at the latest.

2 Basic conditions for the planning and execution of architectural concrete components

2.3 Codes of Practice

Formlining Class FC 1

Formlining and formwork systems from rental parks which correspond to the "Quality Criteria for Rental Formwork Guideline" issued by the Güteschutzverband Betonschalungen e.V. (German Quality Protection Association for Concrete Formwork), can be used for this formlining class without hesitation.

Formlining Class FC 2

Formlining and formwork systems from rental parks which correspond to the "Quality Criteria for Rental Formwork Guideline" issued by the Güteschutzverband Betonschalungen e.V. (German Quality Protection Association for Concrete Formwork), can be used for this formlining class without hesitation. If necessary, individual elements which have been damaged by an internal vibrator or are badly scratched are to be replaced. For sheets coated with phenol resin, e.g. Fin-Ply, the colour of the concrete can vary due to different utilization rates of the elements.

Formlining Class FC 3

With the use of formwork systems from the rental park, elements with new, undamaged formlining are to be used. When using panel formwork with demands on the texture (Table 2 of the DBV Code of Practice "Architectural Concrete"), it must be checked whether the frame impression of the element can be tolerated. Project-related formwork elements (standard elements or specially-joined panels) consisting of system components with new formlining fulfil Formlining Class 3 requirements if used appropriately. Note: regarding how long the formlining can be used for the respective architectural concrete surface is to be checked by the contractor each time before further use.

2.3.2 DBV Code of Practice Concrete Formwork and Striking Times (Version 09/2006)

The DBV Code of Practice contains references to the calculations, structural detailing as well as removing scaffolding and striking of formwork.

This Code of Practice contains the sections:

4 Removing scaffolding and striking formwork,

5 and **Appendix A**, Examples for determining striking times and permissible loads with and without auxiliary support are to be taken into account, as only general statements are given in DIN 1045-3 Amendment 1:2013-07; Version 07/2013, Section 5.6 Removing Scaffolding and Striking Formwork.

2.3.3 DBV Code of Practice Ability to concrete structures made of concrete and reinforced concrete (Version 2004, withdrawn 2014)

This Code of Practice is decisive for verifying the ability to concrete structural components. Instructions are given for:

- the reinforcement arrangement whilst taking into account the ability to concrete (concreting openings, vibration points, rod spacing of reinforcing steel),
- the concrete cover of the reinforcement,
- built-in components and box-outs,
- construction joints,
- execution of the construction work with installation of the reinforcement and concrete placement.

2.3.4 ATCC – Additional Technical Contractual Conditions

The German Federal Highway Research Institute has introduced the ZTV-ING. "Zusätzliche Technische Vertragsbedingungen und Richtlinien für Ingenieurbauten" (Additional Technical Contractual Conditions and Guidelines for Engineering Structures) which are legally binding. The previous technical contractual conditions for civil engineering structures (ZTV-K) have been incorporated in the ZTV-ING.

In Part 3 Solid Construction, Section 2 Execution of the Construction Work, the following is included for formwork:

4.3 Formwork

4.3.1 General requirements

- (1) The arrangement of the formwork must allow the correct installation of reinforcement and pre-stressing tendons as well as concrete compaction to take place.
- (2) The formwork must be so installed that the concrete is neither unsettled nor damaged during striking.
- (3) Formwork made of wood, steel as well as panels which are coated, if necessary, with plastic is permissible. The use of formwork made of other materials (e.g. hard

fibre boards, corrugated steel panels, expanded metal, reinforced concrete slabs) is not permissible.

- (4) Concrete edges are formed by means of chamfer strips.
- (5) Anchoring the formwork with tie wire is not permissible. Formwork ties which leave continuous cavities may not be used with pressurized water. Tie holes are to be carefully plugged with fine concrete of a suitable colour, cleanly inserted, or closed with deeply bonded cement-bound plugs so that the holes are watertight. The proposed type is to be agreed with the client.
- (6) Remaining tie components must end at least 4 cm under the concrete surface in conical recesses. Spacers made of wood are not permissible.
- (7) Before concreting takes place, the functionality of the formwork and its ties are to be checked by the contractor. During concreting, they are to be regularly monitored so that if any deformation occurs, countermeasures can be immediately taken.

4.3.2 Formwork for visible concrete surfaces

- (1) For special demands on the design, the arrangement and formation of the formwork on visible areas (e.g. direction of the formwork boards, joints, joint sealing, formwork flaps and blockouts) are to be shown

schematically. In these cases, drafting of the plan is to be provided in the specifications.

- (2) The formwork is to be installed down to 30 cm below ground level.
- (3) Ties on concrete surfaces remaining visible are to be arranged according to a regular grid pattern. Their number is to be restricted by suitable design of the formwork where possible.
- (4) Glued wood is not permissible for board formwork.
- (5) For board formwork, boards with sharp edges, undamaged, at least 8 cm and maximum 12 cm wide are to be used. Coarse boards must be at least 24 mm, planed boards at least 22 mm thick. Rounded edges are to be formed with fillets. Board joints are to be staggered.
- (6) The joints of the panel formwork must be adjusted in their grid pattern to suit the shape of the building and also cut to match the slope where necessary. Supplements to the formwork through board strips or wedges are not permitted on visible surfaces. Only thin sheets of the same type may be used as formwork panels on a stiff base formwork.
- (7) Tie holes in cantilevered parapets are not permitted. Formwork without longitudinal joints is to be used for cantilevered parapets.

2.3.5 Publication of the GSV (Güteschutzverband Betonschalungen e. V.)

The GSV publication has been compiled as a supplement to the DBV Code of Practice "Architectural Concrete". It contains recommendations regarding planning, tendering and the use of formwork systems for the realization of concrete surfaces with demands on the appearance in accordance with the current state of technology.

Content

- Basics of planning/monitoring and the environment.
- Features of concrete surfaces with requirements regarding the appearance as a reflection of the formwork used
- Non-fulfillable requirements.
- Normative regulations and definitions of the term "architectural concrete".



3 Architectural concrete – call for tenders, award of contract and realization

3.1 List of tasks in the specification

The basic requirements for fulfilling the wishes of the clients and architects regarding architectural concrete surfaces are:

- a clear list of tasks,
- an implementation offer which fulfils the list of tasks,
- implementation planning which facilitates the fulfilment of the list of tasks.

This appears to be logical but, as is shown in practice, is extremely difficult to realize. In the following section, the problem is presented in more detail and possible solutions identified.

In the VOB (Contract Procedure for Construction Work) Part A § 9 Performance Specification, General Information, it is required that:

- "(1) The work is to be described clearly and in sufficient detail so that all bidders can understand the description in the same way and are able to calculate their prices with great certainty and without extensive preparatory work.
- (2) No unusual risk may be imposed on the contractor regarding circumstances and events over which he has no influence, and whose effects on the prices and deadlines cannot be estimated in advance.
- (3.1) In order to ensure correct price calculations, all influencing factors are to be determined and specified in the documents for invitation to bid.
- (3.2) If necessary, the purpose and the intended demands of the finished work are also to be indicated."

In the VOB Part C DIN 18331:2016-09 (Issue date 2016-09), it is stipulated that:

- "0.2 Details of execution.
0.2.4 For visible concrete surfaces, and more
- classification of the visible surfaces,
 - surface texture, description of the formwork and formlining systems if necessary, surface design of non-formed areas,
 - colour shade,
 - surface structure,
 - formation of joints, edges, ties and tie holes as well as formwork joints,
 - number of test surfaces, selection of the reference surface."

In DIN 1045-3, Amendment 1:2013-07, Edition 07/2013, architectural concrete is looked at in more detail in Section 4.2.4 Building Specification:

- "(1) Information which is required for the execution of the building work, verification of the drawings or static calculations, but which cannot easily be inferred from the documentation in accordance with 4.2.2 and 4.2.3, must be included in a building specification and described accordingly. In addition, this includes the information required for concrete with designed visible surfaces."

These basic principles should not only be featured in the call for bids and awarding of contracts according to the VOB, but also complied with in practice. The contractor can only offer the required service if he actually knows what the client expects and if this is the situation, the client is then in a position to make demands.

From [1]: "The documents required for the execution of the building work are to be put at the disposal of the contractor. In addition, this includes providing details regarding the building requests for the visible surface... Without the full particulars for the architectural concrete quality, the client has not fulfilled his obligation. This means the contractor is held back. The contractor must then ask the client for clarification prior to execution."

There is no binding definition in the technical (e.g. in the DIN standards) or legal sense by which the extent of work required for realizing a structure or structural component in architectural concrete is more closely defined. This is a reason why differences could arise between contracting parties whether the contractor has complied with his contractual obligations during the construction of a structure or structural element in architectural concrete.

From [1]: "Because architectural concrete is associated with design, the architect responsible for the planning is required to provide a performance package whose compliance with guarantees a certain appearance. Just how the architectural concrete should look must be determined beforehand. The

term "architectural concrete" is essentially meaningless."

3 versions of tendering are available to the architect:

- Version 1: Objective
- Version 2: Method specification
- Version 3: Method specifications and objectives combined.

Version 1

The architect specifies only the requirements on the visible concrete surface as the objective (reference value through requirement criteria). The decision on how to proceed, and thus achieving the given objective, is left to the contractor (i.e. materials and method).

Version 2

The architect can define an architectural concrete surface through a method description (contractual requirements). The type of work along with the methods described in the performance specifications influences the appearance and thus the suitability of use. That which is typical and characteristic for the

specified type therefore has an effect on the contractually stipulated suitability of use.

Version 3

The architect can combine both (objective and method). The performance specifications then contain the specifications regarding how (method specifications, work description = contractual requirements) and also an exact description of the objectives (= reference value). With this method, the planner provides detailed information in the formwork plans on formwork materials, release agent, formation of the joints, ties, etc. and in so doing combines a detailed description of the objectives.

This type of objective and method specification puts the contractor in a position where he can express his doubts if both aspects do not fully match. This kind of call for tenders provides the most optimal results and ensures that the assignment of tasks is carried out correctly and fairly – the client provides takes care of the planning and the contractor for professional execution.

DBV Code of Practice "Architectural Concrete"

The responsible architect is well advised if possible to classify his design concepts according to one of the 4 architectural concrete classes contained in the Code of Practice (for architectural concrete classes and associated requirement criteria, see Section 2).

3 Architectural concrete – call for tenders, award of contract and realization

3.2 Analysis of the tender

If a tender for an architectural concrete structural component or structure has been presented for offer processing, an analysis of the tender is urgently required as the first step. A check must be carried out to confirm if all required documents in which requirements relating to the respective task, here "concrete surfaces with special requirements", have been handed over or acknowledged.

This may include:

- general technical preliminary remarks
- performance specifications / service specifications
- drawings
- references to DIN guidelines
- references to requirements taken from codes of practice (codes of practice are not included in recognized engineering rules). A comprehensible description must be featured in the tender documentation showing which requirements have been addressed. A general reference to codes of practice is insufficient.)

If the complete list of task assignments has been presented, this is then to be analyzed. Individual requirements are to be compiled from the documents which have been handed over and assigned to the person responsible.

These include requirements for:

- formlining including mounting fixtures,
- formwork system,
- tie system and arrangement,
- release agent,
- reinforcement (\emptyset , spacing, layout),
- mounting parts, box-outs, stop ends, etc.
- concrete formulation,
- concrete placement technology,
- concrete curing,
- acceptance and evaluation.

If compilation of the requirements has taken place, this must be evaluated on an individual basis regarding the feasibility according to the following:

Normal; can be realised without any increase in time and expense = Requirements can be guaranteed.

Can be realised without any increase in time and expense = Requirements can be guaranteed.

Requirements which are partially executable = requirements which cannot be guaranteed.

If a requirement cannot be technically guaranteed, this means that under the given site conditions, which are not completely known either at the time of the offer or awarding of the contract (e.g. weather), certain other factors may arise which could bring about another result (e.g. swelling behaviour of the wood, exposure to sunlight, etc.). Unfortunately, these unforeseeable influence factors are ignored in many tenders and, in effect, it is left to chance that only positive influences affect the result.

non-executable requirements = requirements are completely rejected.

Non-executable requirements are to be rejected in all cases. According to VOB (Contract Procedure for Building Work) Part A Section 9 (2), a contractor may not be given any unusual risk.

Note: [1] "If realization of the work which has been promised to be carried out fails due to the technical possibilities, and cannot be executed better than that which has actually been achieved, then the warranty for defects still applies. The contract is not invalid because of impossibility.

The promise of the quality (reference value) becomes the parameter for the evaluation of the fault-free finish regarding the execution of the agreed work."

"Anyone implicitly promising that which is only partially executable, enters into a legally binding undertaking. This individual is responsible for the failure to deliver because the contract is not invalid in this situation and the material defects of the contract for services is not connected to any blame or feasibility as far as removal of defects and mitigation are concerned."

Executable and thus guaranteed requirements are included in the service agreement according to VOB Part A § 5 (1).

Requirements which can only be fulfilled to a limited extent, and thus are not under warranty, are associated with an execution risk. In order to not leave the executing party alone with the cost risk associated with this, these requirements should be listed in a cost reimbursement contract according to the VOB (German Construction Contract Procedures) Part A § 5 (3).

"(3.1) As an exception, construction work carried out on a larger scale may be allocated according to prime costs if, before awarding the contract, it cannot be laid down in clear and exhaustive terms that a correct price determination is possible (cost reimbursement contract).

(3.2) During the awarding of a contract, it must be determined how wages, materials, equipment provision and other costs, including the overhead expenses, are to be remunerated and how the profit is to be calculated.

(3.3) If a correct price determination becomes possible during the execution of the construction work, a service agreement is to be concluded. If the work performed so far is not included in the service agreement, attention must be paid to ensure clear performance limitations."

3 Architectural concrete – call for tenders, award of contract and realization

3.2 Analysis of the tender

Examples taken from tender document wording with requirements which cannot be guaranteed or implemented:

Example text	Evaluation	Reason
<p>"Formwork featuring new veneer-bonded formwork panels made of resin-coated plywood, minimum thickness 18 mm, without steel edge protection for a completely smooth, matt and untextured concrete finish."</p>	<p>not executable, therefore rejected</p>	<p>Plywood bends; Based on plywood tolerances from DIN 68792:2016-08 Issue date 2016-08 untextured concrete finish = contrast with matt concrete finish = porous film coating</p>
<p>"Formwork joints: "A neoprene strip is to be inserted between the formwork panels. This is to be compressed to a width of 3 mm and should be flush with the panel. The result is a 3 mm wide rough strip on the surface."</p>	<p>not executable, therefore rejected</p>	<p>Plywood tolerance according to DIN 68792: 2016-08 Issue date 2016-08 (= ± 3 mm) do not allow this level of joint accuracy.</p>
<p>"Rippled formwork panels or boards with rippled edges may not be used. New, unused formwork panels are to be used for each concreting cycle."</p>	<p>cannot be guaranteed</p>	<p>Due to the requirement for new panels, rippling can occur through the absorption of moisture via the edges which then disappears again with further use.</p>
<p>"The grid of the architectural concrete areas is: max. 3.00 m x 3.00 m for slabs and max. 3.00 m x 1.50 m for the walls. This means the formwork panels measure 2.999 m x 2.999 m for slabs and 1.499 m x 2.999 m for walls and parapets. The joints are to be sealed along the complete length with sponge rubber. The sponge rubber is to be selected and attached so that a 2 mm wide and 1 mm recessed joint is formed. In other words, the sponge rubber must overlap the formlining surface by 1 mm."</p>	<p>cannot be guaranteed or implemented</p>	<p>See previous text regarding plywood tolerances</p>

Example text	Evaluation	Reason
<p>"The highest demands are placed on the tolerances. At the very least, tolerances in accordance with Table 3 Line 7 in DIN 18202:2013-04 Issue date 2013-04 for all architectural concrete structures are to be observed."</p>	cannot be guaranteed	<p>Additional requirement: plywood screwed on at the rear = 2 sheets of formlining on top of each other = double tolerance DBV Code of Practice, Table 2: "High demands on levelness, e.g. DIN 18202:2013-04 Issue date 2013-04, table 3, line 7 are technically not accurately feasible."</p>
<p>"Basically, all edges are to be formed as sharp edges." For architectural concrete areas, the following are to be ensured:</p> <ul style="list-style-type: none"> ■ No formation of nests and pores, ■ No evidence of streaks, ■ Colour uniformity, ■ No visible impressions caused by reinforcing bar spacers. 	cannot be guaranteed	<p>DBV Code of Practice, Section 5.1.2 Feasibility: "Technically cannot be produced or resulting quality cannot be guaranteed: non-bordered sharp edges with no minor breakage and bleeding, pore-free visible areas, uniform colour of all visible surfaces."</p>
<p>"The formwork is designed to handle the silo pressure of the fresh concrete whereby a time lag is to be taken into consideration for the setting of the concrete. This time is to be determined in agreement with the structural engineer and the concrete technologist of the contractor. The formwork for the architectural concrete surfaces with high requirements is to be pre-tensioned by means of special clamping devices to suit the corresponding concreting pressure. Tensioning reports are to be compiled and be submitted to the site management before concreting begins."</p>	Not executable	<p>For the formwork, the fresh concrete lateral pressure according to DIN 18218:2010-01 Issue date 2010-01 applies. Silo pressure is not present with fresh concrete.</p> <p>Pre-tensioning the formwork anchors requires suitable pressure resistance in the formwork which accommodates the pre-tension forces through to the active concrete pressure. The concrete pressure cannot be exactly determined.</p>
<p>"All construction measures are to be carried out to ± 3 mm accuracy; dimensional inaccuracies are to be eliminated at the expense of the contractor."</p>	Not executable	<p>With a building length of approx. 67 m, a tolerance of ± 3 mm is already required of the measuring equipment.</p>

4 Architectural concrete – formwork (system formwork)

4.1 Wall formwork

In modern concrete construction, system formwork or formwork is primarily used which consists mainly of system components. Conventional formwork and special constructions play a subordinate role and are utilized only for special formwork tasks.

Formwork systems are divided into two main groups according to their main design features:

- **Panel formwork** (with slab panel formwork),
- **Girder formwork** (with slab flexible formwork).

A general description of these formwork systems is not possible at this point; please refer to the relevant specialist literature (e.g. PERI Formwork Handbook). The effects on the concrete surface and, in turn, on the architectural concrete surfaces are described in the following using the example of the PERI formwork systems.

Panel formwork

The principle of the panel formwork is represented through the PERI TRIO system. Other panel formwork systems are similar in their concrete finish. The grid pattern of the framed panels and the formwork ties varies from system to system. Main elements are the panelized formwork. The formlining is inserted into stiffened frames made of special metal profiles.

The grid dimensions of the element widths and heights is usually 300 mm or 250 mm.

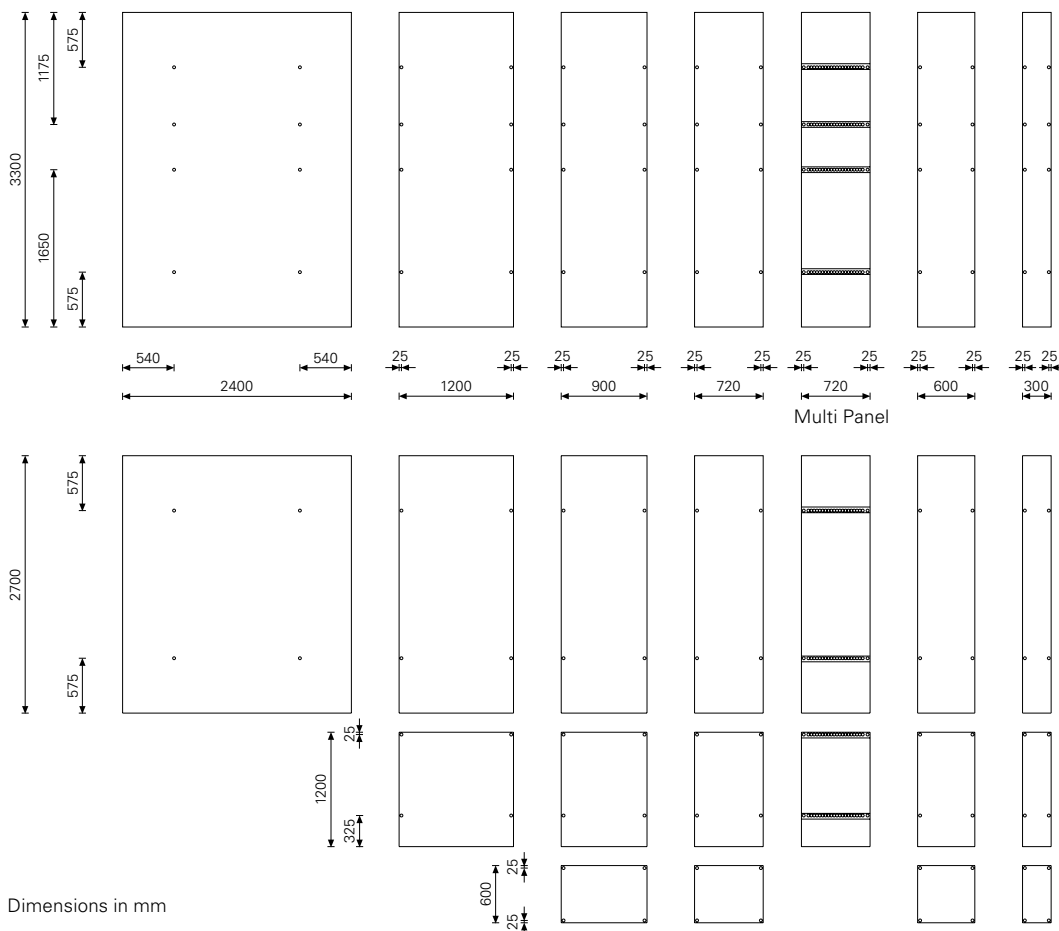

TRIO Panel Formwork – overview of panel impressions on the concrete surface

Special formwork couplings connect the formwork panels to each other according to the BFD principle ("flush-aligned-tight"). Due to the protruding edge profiles of the panel, the formlining sheets are protected along the edges. Smooth, film-coated, non-absorbent formwork panels are used as formlining. Plywood is mainly used as the supporting material. All-plastic sheets are utilized in part. The panel joints provide a typical panel formwork impression.



Concrete wall formed with PERI TRIO taken from the rental park; Formlining Class FC 1

The tie hole positions for installing the formwork ties are pre-determined in the panel formwork. This results in a fixed system-specific tie spacing. Due to this arrangement in the panels, not all tie holes are required for the formwork anchorage. These must be closed by means of plastic plugs which subsequently leave an impression on the concrete surface.

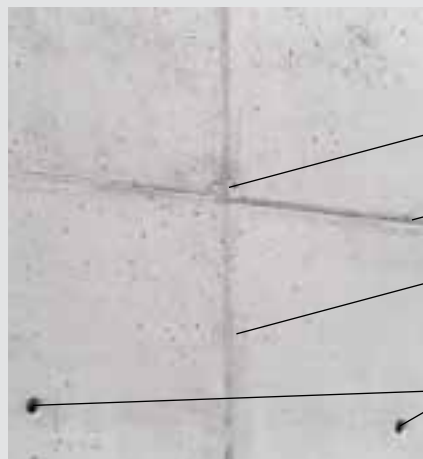

- Impression of a tie hole which was not required and closed using a plastic plug
- Frame impression of the formwork panel
- Properly executed repair on the formlining
- Unplugged tie holes

Details of previous photo

4 Architectural concrete – formwork (system formwork)

4.1 Wall formwork

The construction of wall corners and wall T-junctions is structurally determined through special internal corner units and the tie hole positions in the system. This results in a typical pattern of the panel joint and tie arrangement also on the concrete side opposite.

For larger formwork heights, the formwork panels are arranged as extensions and show horizontal joints on the concrete surface. Due to the standard panels and specified tie spacing, the maximum permissible load on the formwork through the fresh concrete pressure is pre-determined.

Quality of the panelized formwork:

Due to their construction, panel formwork systems are very robust and have been designed for high rates of utilization. Sufficient stocks are held by formwork providers in their respective rental parks. Through the multiple use of each individual formwork panel, this can result in different utilization rates as well as exhibiting repaired areas. The quality of the rental formwork is regulated in the rental formwork information booklet^[1] and in the quality guidelines of the formwork provider. The standard used and correctly repaired rental formwork is to be classified according to the DBV Code of Practice "Architectural Concrete"^[2] in Formlining Class FC 1 to FC 2.

^[1] GSV = Güteschutzverband Betonschalung e.V. (Quality Protection Association for Concrete Formwork) Instructional Booklet 3 Rental Formwork (June 1999)

^[2] DBV (Deutscher Beton- und Bautechnikverein e.V. – German Society for Concrete and Construction Technology) Code of Practice "Architectural Concrete" (Version 06/2015)

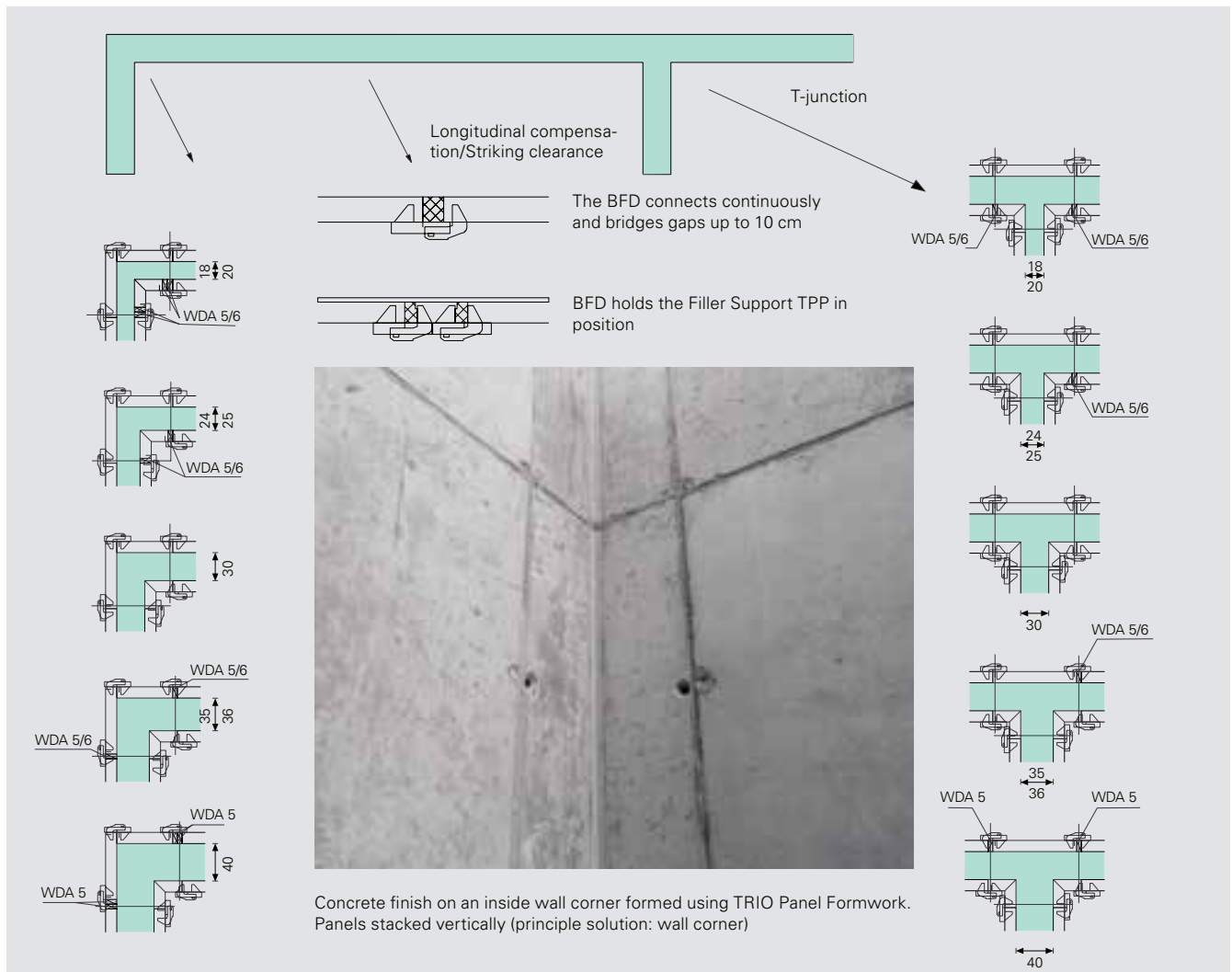

A higher surface quality can be achieved if the formwork panels are fitted with new formlining sheets. This represents an extra service which has to be compensated separately. This formwork is to be classified according to the DBV Code of Practice "Architectural Concrete" in Formlining Class 2 (or possibly Formlining Class 3).



Filler areas were symmetrically arranged here. The formlining used here corresponds to that which is also used in the adjacent formwork panels.

Concrete wall formed using PERI MAXIMO.
Panel fitted with new formlining.
Architectural Concrete Class 2



4 Architectural concrete – formwork (system formwork)

4.1 Wall formwork

		Width [cm]					
		240	120	90	60	45	30
Height [cm]	30						
	60						
	90						
	120						
	270						
330							

Using PERI MAXIMO produces a fundamentally different arrangement of the tie points and panel joints. The tie points are arranged in the inner area of the panels. All tie points are arranged vertically one below the other and horizontally on one level. By means of skilful panel planning, there are no unused tie points. This means that all tie points look the same in the final result. Likewise, all panel joints are positioned horizontally or vertically without any offsets.

The elements can also however be deliberately positioned in an offset arrangement. Careful planning is always required when using the PERI MAXIMO for architectural concrete surfaces.

MAXIMO Panel Formwork – panel overview and tie positions



MAXIMO for high architectural concrete requirements AC 3

4 Architectural concrete – formwork (system formwork)

4.1 Wall formwork



Large-sized MAXIMO panels regularly arranged



Horizontal formwork panels, offset by half a width

With some panelized formwork systems, the formlining can be individually selected and, e.g. as with the TRIO Structure, fixed to a supporting panel. The formlining can be freely selected according to the surface requirements.

Whilst taking into account the dimensions of the pre-assembled formwork sections, formlining formats can also be freely determined.

The panel joint design and arrangement are determined by the formlining. The formlining covers the frame profile edges resulting in no frame impression on the concrete surface.

As two formlining sheets are positioned one on top of the other, the swelling values (thickness tolerance) of both sheets are to be taken into consideration. Offsets in the joint areas cannot be ruled out. Formlining sheets are therefore unsuitable for a panel-overlapping arrangement.

The main area of use is concrete surfaces with boards as architectural concrete formwork, particularly in bridge construction (visible side: TRIO Structure with board formlining; rear side: standard TRIO formwork from the rental park).

Attaching the formlining usually takes place at the front (concrete side); with a formlining thickness of ≥ 21 mm, fixing can also be done at the rear. This represents an increase in the work required. The TRIO tie spacing is the same for the TRIO Structure as the same frame panels are used.

Through the installation of filler timber in the panel joints along with ties in the filler timber itself, the tie spacing can be changed.



Wall constructed with TRIO Structure

4 Architectural concrete – formwork (system formwork)

4.1 Wall formwork

Examples of a concrete finish using TRIO 330 Panel Formwork – details



Large panel, formlining sheet central joint with rivet impressions, nailed to Structure



Element joint without any additional sealing, tie holes closed with plugs



Internal corner element with Wall Thickness Compensator



Details from left photo. Formlining/edge angle joint on the internal corner element



Panel joint without any additional sealing, leakage of fine particles possible!



Concrete finish using a multi-purpose panel



Internal articulated corner with connecting steel fillers



Internal articulated corner – details of the corner (hinged construction)

4 Architectural concrete – formwork (system formwork)

4.1 Wall formwork



Articulated corner, steel filler and standard panel details; tie points sealed by means of plastic plugs



Unused tie points in the large panel; sealed with plastic plugs



Stopend formwork used in the panel formwork, bevelled edges using timber chamfer strip



MAXIMO tie point sealed with a fibre cement plug

Girder formwork

The girder formwork principle is illustrated using high-tensile PERI VARIO as an example. Other girder formwork systems produce similar concrete impressions. The grid arrangement of the standard sections and the formwork ties can vary. The formwork sections (= pre-assembled formwork elements consisting of formlining, main beam and walings) could be:

Standard section = pre-assembled sections available in stock in the rental park with defined panel sizes, equipped in part with formlining for subordinated requirements and as supporting panel for architectural concrete formlining.

From the photo it is evident that a defined panel and tie arrangement in the system are available when using standard elements.

Likewise for wall corners and T-junctions, there are standard solutions which are to be taken into consideration. These standard solutions also apply to object-related pre-assembled formwork elements whereby only small deviations are possible.

VARIO GT 24 standard panels

Height increments

VARIO standard panels are available in 60 cm increments.

These panels are simply extended for realizing greater heights.

Base panel for extension, without top cover

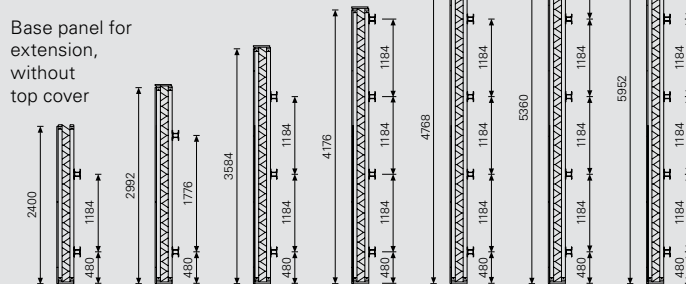

Fitting / striking clearance

Maximum compensation widths with VARIO Couplings VKZ

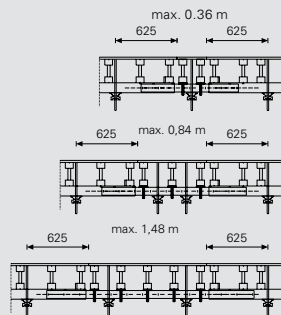

System width

VARIO standard panels are available in 3 widths

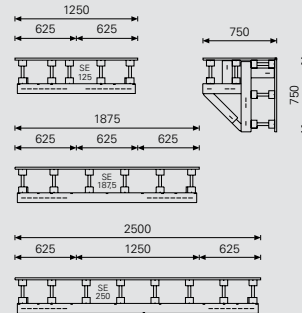

Corner solutions

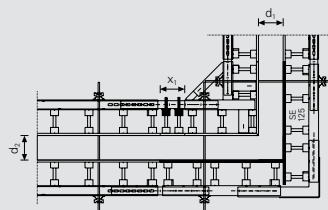

T-junction

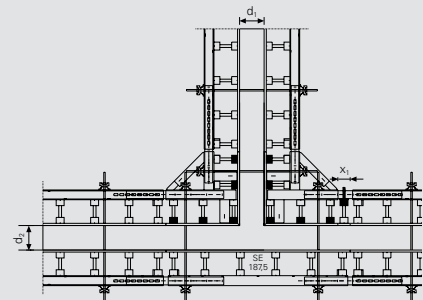

4 Architectural concrete – formwork (system formwork)

4.1 Wall formwork

VARIO GT 24 – object-related formwork

Object-related formwork sections = as before but the formwork sections are planned and manufactured according to the special requirements. In the process, the formlining (type, size, mounting), girder and waling (spacings) as well as the tie arrangement are freely selectable whilst taking into account the system's basic principles. The load-bearing capacity of the formwork can be varied through the girder, waler and tie spacings.



VARIO – high-tensile, project-specific, pre-fabricated elements on two storeys.



VARIO – high-tensile, project-specific, pre-fabricated elements



An offset of the panels at the joint up to 5 mm can be eliminated through the use of the Coupling VKS.

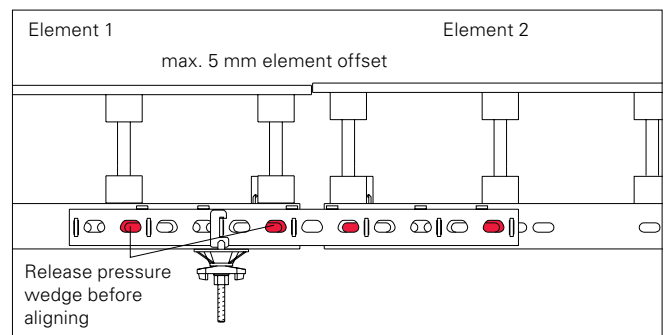

Curved walls

can be constructed with system formwork.

Polygonal panel formwork with chamfer strips in the joints

Compared to the TRIO, using MAXIMO has the advantage that it does not have to be anchored through the inserted trapezoidal strips. As a result, the trapezoidal strips can be very thin if required and must not be drilled.



Curved walls of a container formed using TRIO elements with trapezoidal strips inserted in the joints.



Curved wall formed with MAXIMO elements with trapezoidal strips inserted in the joints.

4 Architectural concrete – formwork (system formwork)

4.1 Wall formwork



Girder formwork with adjustable bending radii

This is a girder formwork system whereby the waler position can be varied lengthwise by means of adjustable spindles thus permitting the formation of a concave or convex curvature.

Depending on the formlining, bending radii ≥ 1.00 m are possible.

The elements are available in stock as rental formwork. Regarding the concrete surface quality which can be achieved, the same applies as stated for panel formwork taken from the rental park. This means that the formwork is to be classified as Formlining Class 1 to 2.



Architectural concrete wall formed with RUNDFLEX

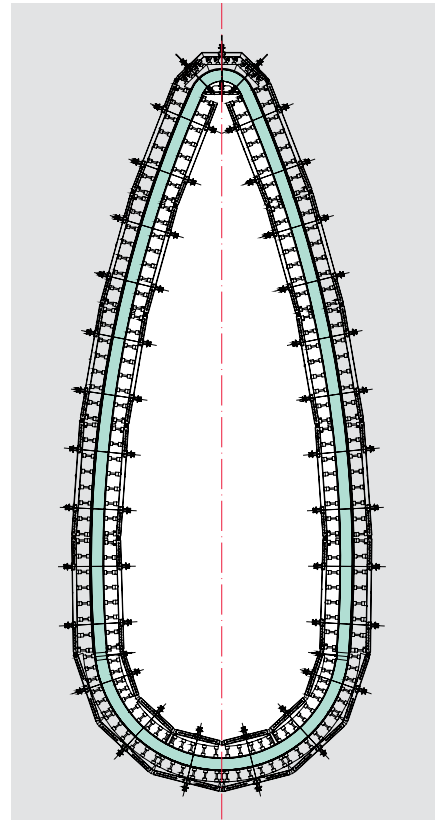

If the version using system girder formwork is insufficient, a special formwork construction is to be designed. Where higher specifications are required, girder formwork is used (e.g. high-tensile PERI VARIO). Cut-to-size segmental boards are mounted on the girder grid, after which the formlining is attached. The type and size of the formlining are freely selectable. The sheet thickness is to be selected according to the bending radius, moisture content of the formlining sheet and the supporting direction. Due to the bending movement of the sheets, attachment of the formlining is only possible from the concrete side. Attachment at the rear is only possible after obtaining the agreement of the formwork provider; however, this is problematic due to the small anchoring depth in the formlining.

Stairwell walls, ground plan with changing radii.
Formed with VARIO elements and double-layered profiled timber

4 Architectural concrete – formwork (system formwork)

4.2 Column formwork

Column formwork can be classified according to the following features:

- Panel formwork
- Girder formwork
- Steel formwork

Depending on the design principle, different concrete surface qualities can be achieved. The quality actually realized depends on the type of formwork and is presented using the following PERI column formwork systems.

Panel formwork types



TRIO Column Formwork

Column cross-sections up to 75 cm x 75 cm in 5 cm increments can be built with this formwork. The panelized elements with 90 cm widths are specially designed for use as column formwork and are equipped with rows of holes for corner connections. Which leave small impressions on the concrete surfaces. The framed formwork panels are erected in a so-called windmill fashion. The required formwork height is achieved by combining element heights of 2.70 m, 1.20 m and 0.60 m. When extending, horizontal joints are formed, very similar to the element joints when using TRIO panel formwork.

The corners are formed and sealed by means of specially-attached plastic chamfer strips. Creating sharp-edged corners is only partly possible even with additional joint sealing.

As standard, the framed formwork panels are fitted with non-absorbent, film-coated multi-layer plywood sheets. They are available from the rental parks and comply with rental formwork quality guidelines. The formwork is classified as Formlining Class FC 1.

Column formed with TRIO Column Formwork



QUATTRO Column Formwork

Column cross-sections of up to 60 cm x 60 cm can be constructed in 5 cm increments. The frame formwork panels are erected using what is referred to as windmill fashion and are connected to each other outside of the plywood formlining. The formwork height is limited to 4.00 m (with 80 kN/m² concrete pressure) and is reached by combining element heights of 3.50 m, 2.75 m, 1.25 m and 0.50 m. The all-plastic formlining sheet is screwed on to the panel frame at the rear.

When extending, horizontal formlining joints are formed. The corners should be formed using plastic chamfer strips. Without chamfer strips, the use of an additional sealing strip (sponge rubber) facilitates the creation a tidy sharp edge.

The formwork is stored in the rental park according to rental formwork quality guidelines. It is classified as Formlining Class FC 2.

Column formed with QUATTRO, the formwork features a double height extension



RAPID Column Formwork

Column cross-sections ranging from 20 cm x 20 cm up to 60 cm x 60 cm and, with additional formwork anchors, from 85 cm x 85 cm up to 130 cm x 130 cm can be constructed using any rectangular cross-section. The formlining (21 mm thick) can be freely selected depending on the concrete surface requirements, and is customised according to the column cross-section and clamped in the framed panels using chamfer strips.

The concrete surface is influenced only by the type of formlining used. With the use of 30 mm thick formlining, the formation of sharp edges is possible. The maximum possible column cross-section is then 58 cm x 58 cm.

As the formlining is supplied to match the project requirements, the formwork can be classified up to Formlining Class FC 3.

Column formed with RAPID Column Formwork, edges bevelled through the use of chamfer strips



Corner details: RAPID Column Formwork with 30 mm thick formlining without chamfer strips for sharp-edged columns.



Corner details: RAPID Column Formwork with 21 mm thick formlining and chamfer strip

Column formed with RAPID Column Formwork. Sharp-edged version without chamfer strips

4 Architectural concrete – formwork (system formwork)

4.2 Column formwork

Girder formwork

VARIO GT 24 Column

The formwork is planned and assembled to match the project requirements and consists of formlining, formwork girders and steel column walers. This means that the formwork can meet the concrete surface requirements in the same way as girder wall formwork. Fixing the formlining from the rear is possible and is seen as an additional service. The concrete finish is principally determined by the formlining selected and its fixings to the girders. Additional formwork ties through the column may be required for large column cross-sections. Corners are formed by means of chamfer strips. Through the use of additional sealing strips (sponge rubber), it is possible to form sharp edges with the formwork.

As the formlining is supplied and fitted to match the project requirements, the formwork can be classified up to Formlining Class FC 3.



Column formed with VARIO Column Formwork

Circular column formwork

PERI GRV Articulated Waler Formwork for circular columns

A special type of girder formwork is the Articulated Waler Formwork. The articulated walers enclose the column in the form of a polygon and absorb the fresh concrete lateral pressure via ring tension forces. The formwork is planned and assembled to match the project requirements. In so doing, the formlining can be freely selected to meet the concrete surface requirements. Due to the curvature, the formlining is fixed to the girders only from the concrete side. With the use of individual boards as formlining, segmental boarding is mounted to the vertical formwork girders in order to achieve the required curvature.

The formwork can be classified up to Formlining Class FC 3.



Column formed with articulated waler formwork

4 Architectural concrete – formwork (system formwork)

4.2 Column formwork



Steel circular column formwork

Special formwork for circular columns with fixed diameters (\varnothing from 25 cm to 120 cm in 5 cm increments).

2 semi-circular forms with powder-coated metal formlining and panel lengths of 3.00 m, 2.40 m, 1.20 m and 0.30 m are available. The required formwork height is achieved through a combination of these panels.

The panel longitudinal and lateral joints are shown on the concrete surface in the form of narrow lines.

The formwork is available as rental formwork up to a diameter of 70 cm and can be classified in Formlining Classes FC 1 and FC 2.

Column formed with VARIO Column Formwork



Formwork tubes (single-use formwork)

For circular as well as square-shaped columns, so-called formwork tubes are available. These are created from special paper and foil. For non-circular column cross-sections, pressure-resistant foam inserts can also be used. They have been designed for single usage. Due to the coating, the formwork has a non-absorbent effect on the concrete surface. The winding design of the tube is reflected on the concrete surface by a faint spiral line.

A surface without any impressions can be achieved through the addition of a fitted plastic hose. Available diameters and cross-sections, as well as special application instructions, are given in the details provided by the individual suppliers.

Depending on the design, the formwork can be classified in Formlining Classes FC 2 and FC 3.

Column formed with a formwork tube

4 Architectural concrete – formwork (system formwork)

4.3 Slab formwork

According to the construction principle, both wall formwork and slab formwork are divided into three groups as follows:

- Panel slab formwork
- Girder slab formwork (flexible slab formwork)
- Large-sized formwork (slab tables)

The specific concrete surface quality achieved depends on the type of formwork used and is presented through the various PERI slab formwork systems that follow.

SKYDECK Panel Slab Formwork

Panels (similar to the framed panels for wall formwork) are mounted on special girders and leave a typical frame impression on the concrete surface as is found with panel formwork used in wall construction. The grid is determined by the size of the panels and is different for each of the systems on the market. For SKYDECK, the following panels are used:

Basic elements

- 150 cm x 75 cm
- 75 cm x 75 cm

Filler elements

- 150 cm x 50 cm
- 75 cm x 50 cm
- 150 cm x 37.5 cm
- 75 cm x 37.5 cm

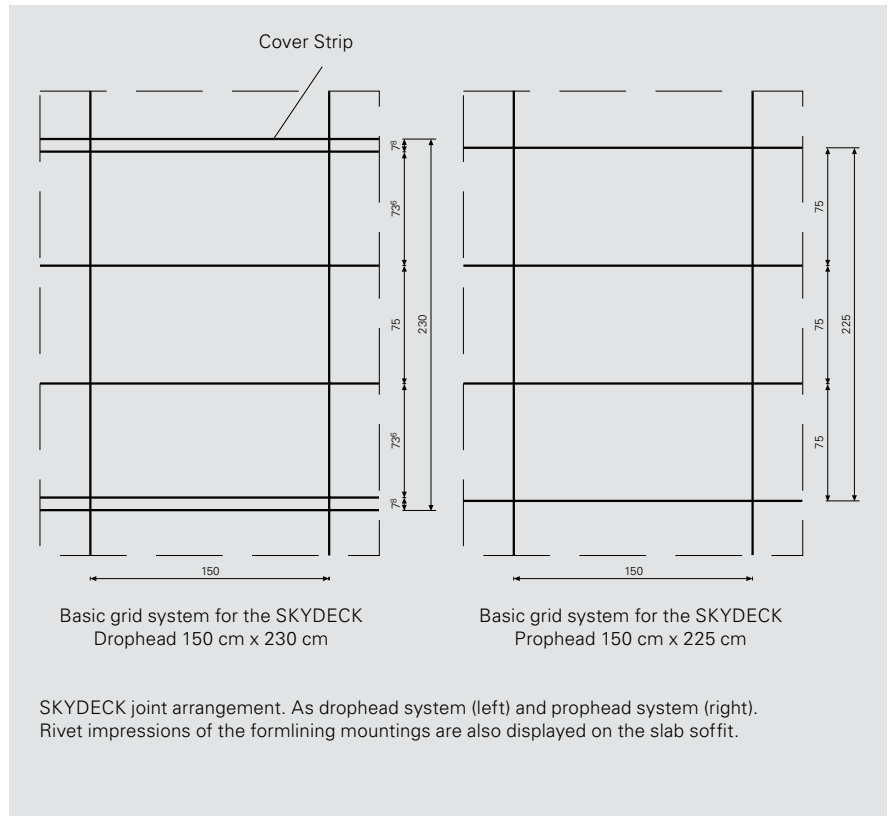

Using filler elements reduce time-consuming fitting in the edge areas, at interruptions (e.g. supports). Any remaining areas and striking fillets are formed using cut-to-size strips of formlining. The arrangement and formation of the filler areas are to be planned according to project requirements.

The basic grid of the SKYDECK is consistently maintained throughout the entire forming area due to the design, and is:

- with the drophead system: 150 cm x 230 cm,
- with the prophead system: 150 cm x 225 cm.

4 Architectural concrete – formwork (system formwork)

4.3 Slab formwork

The formwork is stored in the rental park according to rental formwork quality guidelines. They are classified in Formlining Classes FC 1 and FC 2 – with new formlining, FC 2 and FC 3. Here, the typical panel frame impression left on the concrete surface is to be taken into consideration.

PERI MULTIFLEX flexible system

The individually selected formlining is mounted on a girder grid consisting of special formwork girders (wind-exposed areas are fixed with nails). For minimum surface requirements, 50 cm x 150 cm, 50 cm x 200 cm, 50 cm x 250 cm and 62.5 x 250 cm formwork panels can be used. These are available in part from the rental park.

For stricter requirements, the formlining is to be selected according to the project specifications. The preferred size is the standard format of 125 cm x 250 cm and 62.5 cm x 250 cm with a sheet thickness of 21 mm. Larger sizes should be avoided if possible as these cause problems if striking manually and are easily damaged at the edges.

The finish of the formed concrete surface is determined exclusively by the formlining used. Depending on this, the formwork can be classified up to Formlining Class FC 3.



Slab soffit formed using SKYDECK
Dropheads. Grid: 1.50 x 2.30 m

Slab Tables

TABLE MODULES

Slab formwork tables have a special position regarding panel and formlining grids (= prefabricated units similar to the formwork units of the girder wall formwork). With slab table modules, these are prefabricated formwork units in a pre-determined grid arrangement (PERI modules: 200/215 x 400 cm; 200/215 x 500 cm; 250/265 x 400 cm; 250/265 x 500 cm) complete with formlining (film-coated plywood sheets). The formlining is screwed on at the concrete side.

The slab table modules are standard formwork and available from the rental park. They are to be assessed according to quality guidelines for rental formwork. The table modules are to be classified in Formlining Class FC 1 and FC 2. If it has been agreed to use new formlining (additional service), FC 3 is possible. When using the slab tables, particular attention is to be paid to the required filler areas between the tables during the planning phase and must be agreed with the architect.



Customized tables

In certain projects, customized tables can also be used. In these cases, the dimensions as well as the formlining (type, size, fixing) can be freely selected within the scope of the system boundaries. Customised planning of the table, formlining and filler area grid is essential especially for meeting the architectural concrete requirements. When using slab tables, take into consideration the use of striking fillets which may affect the appearance of the slab soffit. This is to be agreed upon with the architect.

Customized tables can be classified up to Formlining Class FC 3.

Slab soffit formed with table modules from the rental park

5 Formlining

5.1 Preliminary remarks

Through the correct selection of formlining, a large number of design possibilities for the concrete surface structure are possible.

In the process, the formlining determines the surface character of the concrete – independent of any subsequent processing or treatment.

The person responsible for writing the tender documents must have detailed knowledge of the formlining together with the material properties, the coatings and the processing, as well as the interaction with the release agent and the fresh concrete, and take this into account during the planning.

The specifications of the concrete surface must be well-defined so that the contractor can take into account all aspects relevant to the materials and applications without any risk when selecting the formlining to be used. The contractor must be able to assess the feasibility and to point out any expected tolerances and/or fluctuations in the results.

Four properties in the formlining have an influence on the concrete surface

- Absorbency capacity of the formlining
→ light/dark concrete surface
- Surface texture (structure)
→ concrete surface texture
- Formlining joints
→ grid arrangement of the concrete surface
- Fixing of the formlining
→ impressions on the concrete surface

Note

The compatibility of the concrete mix with the formlining surface and release agent is to be checked by the concrete engineer and, if possible, tested before use.

5 Formlining

5.2 Characteristics of the formlining surface

Absorption properties

The formlining surface can be absorbent or non-absorbent. This means that when concreting the concrete edge area, different quantities of water are extracted. The water/cement value of the concrete in the edge area is lowered by the removal of mixing water. If the concrete is compacted by means of vibrators, fine particles and water migrate to the formwork surface.

The water/cement value is therefore increased in this concrete edge area. By means of an absorbent formlining, the water/cement value can be somewhat lowered again. Thereby, the concrete has therefore an improved structure at the edges. For more details on the concrete edge area, see.^[1]

^[1] DBV Progress Report for Concrete Surfaces – Concrete Edge Areas 11/96

Table 5.1 Influence of the absorbency on the concrete surface of the formlining area

Absorbent formlining surface	Non-absorbent formlining surface
Darker concrete surface	Lighter concrete surface
Lower water/cement value of the concrete edge area	Higher water/cement value of the concrete edge area
Lower number of air and water pores on the surface	Higher number of air and water pores on the surface
Somewhat increased tendency for dusting/sanding of the concrete surface	Lower tendency for dusting/sanding of the concrete surface
Grey colour shading through absorption differences in the formlining surface	Less tendency for grey colour shading but strong tendency for cement and fine particle accumulation
Absorption = faster moisture absorption and release, and thus a tendency for swelling and shrinkage	Less tendency for swelling and shrinkage

5 Formlining

5.2 Characteristics of the formlining surface

A general valid statement regarding the absorbency (→ here water absorption from the concrete) is not possible as this depends on various factors such as:

- Moisture content of the wood or wood panels, observance of the intermediate drying process before subsequent use.

- Surface sealing by treatment with cement/lime slurry and release agents.
- Deposit formation of ultra-fine/fine particles from the concrete surface.
- Adjusting the manufacturer's moisture content of the panels (5 – 9 %) to 16 – 20 % processing moisture content.
- Surface coating (moisture permeability of the coating).

Different quantities of water are extracted from the fresh concrete in the concrete fringe area. The statements contained in the following table are to be regarded as orientation and assessed on an individual basis.

Table 5.2 Water absorption properties of the formlining surfaces and approx. frequency of use for architectural concrete

Absorbency level	Formlining and surface	Number of uses for architectural concrete
↑ increasing good moderate poor	Liner (only limited suitability for architectural concrete, risk of wrinkling)	1 to 15 according to manufacturer's instructions
	Timber panels, uncoated (chipboards, OSB panels)	approx. 3 to 5
	Boards, boarded panels, uncoated, untreated	approx. 3 to 5 (possibly 7)
	3-ply panels, uncoated	approx. 5 to 8
	Plywood boards, uncoated	approx. 5 to 8
	Plywood boards with absorbent film coating	approx. 3 to 6
	Paper-wrapped column form, impregnated (column formwork)	1
	Boards, boarded panels, coated	approx. 8 to 12
	3-ply panels and plywood with melamine resin coating	approx. 10 to 15
	Boards (plywood, blockboards of thin or thick laminations, OSB timber panels) film-coated (increase in film thickness results in a decrease in absorbency)	Depends on surface requirements – up to 35, possibly more
↑ increasing very poor none	Paper-wrapped column form with fitted plastic foil	1
	All-plastic panels (composite construction)	Depends on surface requirements, up to approx. 50
	Plastic matrices, foil, tubes	As per manufacturer's specifications
	Metal formlining	Design-dependent



Slab soffit formed using different formwork panels (different surface structure, different absorption properties)

Surface texture (structure, roughness of the formlining)

The surface texture of the formlining is formed on the concrete surface as a negative imprint. In the process, the accuracy of the impression depends on the concrete. Illustrations of self-compacting concrete with a high proportion of fine aggregate are considerably more exact and detailed than vibrated concrete with a low proportion of fine aggregate.

For vibrated concrete, the smoother and more non-absorbent the surface of the formwork is, the greater the tendency for irregularities such as colour fluctuations, clouding, marbling to occur.

Coating of the formlining surface, particularly for structured board surfaces, can homogenize the structure.

Examples of concrete surfaces



Surface texture through boarded formwork: Vibrated concrete



Surface from boarded formwork: self-compacting concrete

5 Formlining

5.2 Characteristics of the formlining surface



Formlining: rough-sawn boards, rough, nailed.



Formlining: 3-ply plywood, brushed surface, coated, with milled grooves.



Formlining: coated boards, planed, clamped.



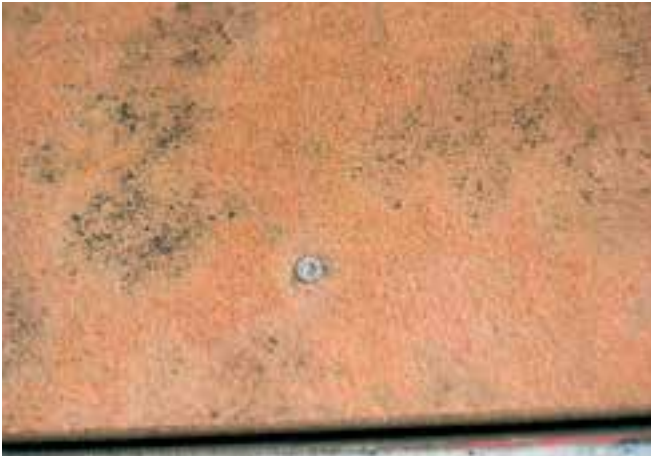

Formlining: WESTAG RS Special wooden composite board, oiled, screwed on.

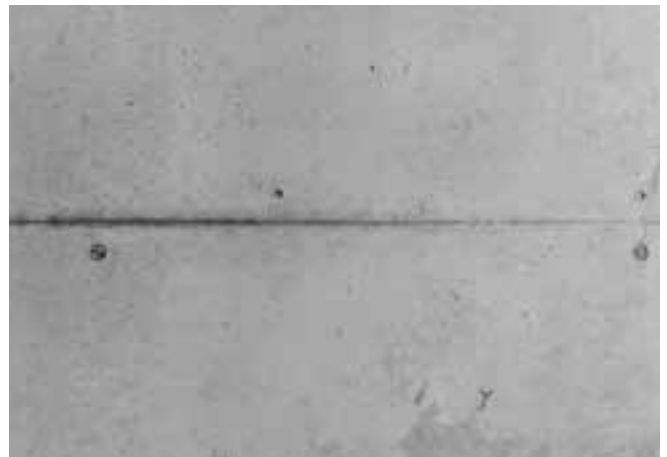

Formlining: film-coated plywood (phenolic resin) PERI Fin-Ply, smooth surface, very poor absorbency.

5 Formlining

5.3 Wood as formlining

Wood properties

Wood is the ideal material for concrete formwork (formlining). Uncoated wood surfaces have a material-related porosity and can lead to moisture exchange with the concrete surface. Cement, as a hydraulic binding agent in concrete, requires water as part of the hardening process (hydration). During the concrete compaction process carried out

by vibrating, moisture-saturated cement paste is transferred to the formlining surface.

Boards with an intrinsic moisture content of approx. 16 to 20% can absorb moisture from the concrete where required. If the concrete requires moisture for hydration purposes, the

boards can release moisture back to the concrete. The board surfaces are therefore different. The "right" side is (growth ring-related) more open and thus more active than the "left" more pore-closed side.

Section through the board formlining – individual boards, butt-jointed

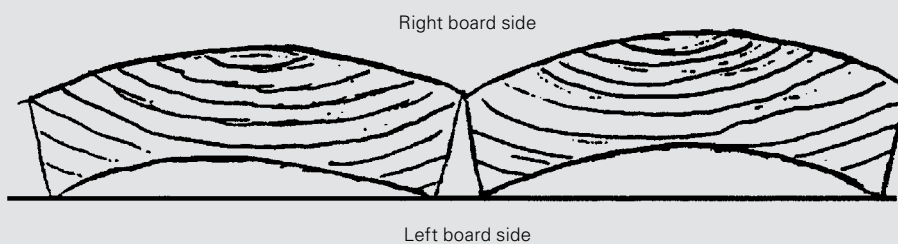

Due to growth ring-related, intensive moisture absorbency and release, this results in a convex curvature in the board cross-section. In the longitudinal joint, this means edge pressure and joint closure against escaping cement and fine/ultra-fine particle slurries. Concrete nib formation in the joint area is substantially reduced, if not practically excluded.

Professional and material-appropriate boarded formwork still ensures designed as well as effective architectural concrete finishes.

Unfortunately, board production and processing (planing, sanding, jointing) in modern sawmills no longer distinguishes between the right and left sides of the board. In order to prevent excessive warping of the cross-section,

relief grooves in part are milled on the back of the board.

For the formlining sheet, an intrinsic moisture content of approx. 16% at the time of assembly is favourable. This wood moisture is realized by means of technical drying. Depending on weather conditions and design, the boards may need to be additionally wetted before concreting. Through treatment with the release agent, moisture absorbency and release can be affected.

Under natural climatic conditions, wood can absorb or release around 3 – 5 % moisture per day from the ambient atmosphere. Changing intrinsic moisture content of the wood leads to swelling and shrinkage (= volume change) in the area up to fibre saturation.

For spruce/fir, fibre saturation in respect of moisture content in the wood is approx. 35%, for birch approx. 29%. A further increase in wood moisture or a decrease down to this value leads to no volume changes in the wood. Due to the macroscopic structure of the wood, the dimensions during swelling and shrinking vary in relation to the growth rings:

- in the direction of the growth rings (tangential), moisture change is the strongest: 0.24%/%
- in the direction of the vascular rays (radial), there is a 0.12%/ change in the moisture
- in the direction of the fibres (longitudinally), there is a slight change in the moisture: 0.01%/%

Growth ring-related board warping during shrinkage

This results in different, characteristic changes in shape of the wood cross sections through swelling and shrinkage, depending on the position in the trunk.



It follows that dimensional changes in the board cross-section in relation to the board length are important and, depending on the growth ring position, can amount to a 0.12 – 0.24%/‰ change in moisture.

Example: for a 10 cm wide board and 5% moisture change, this is 0.6 to 1.2 mm.

5 Formlining

5.3 Wood as formlining

Boards used for formlining should have an intrinsic moisture content of 15 – 20% (i.e. technically dried). However, it is hardly possible to maintain this moisture content level over the working life of the formlining on the construction site. Due to the effects of cement/lime slurry, or coating and release agent treatment, the moisture exchange on the surface can be reduced but not prevented. Humidity, water precipitation, concreting sequences with intermediate drying have an influence on the moisture content of the boards. Thereby, the changes resulting from swelling and shrinkage in the element dimensions (width and length), joint widths and offsets are unavoidable and therefore have to be accepted.

Wood sugar (xylose) and concrete

With uncoated wood surfaces, there is a reaction between the wood sugar in the board surface and the alkaline constituents of the concrete during concreting. The hydration of the cement paste is impaired by the wood sugar on the concrete surface. Dusting may occur on the surface of the concrete and white streaks appear on the surface which do not disappear even if the concrete surface is exposed to weather conditions over a very long period. This situation can be counteracted by neutralizing the wood surface. For this, the board surfaces are coated once or twice with cement slurry (lime slurry for white concrete) before first use. After a short drying period, the paint is brushed off. Thus, the wood sugar is neutralized for the initial use on the board surface.

Important: during prolonged storage, the wood sugar may collect again on the board surface. Re-treatment is then required.

For coated wood surfaces, this measure is not required because the wood sugar does not come into contact with the concrete surface.

Wood surfaces of the formlining

Boards and boarded panels

Rough-sawn surfaces

Boards are sawed from the tree trunk, there is no further processing of the wood surface. Due to modern sawmill technology, the band saw cut is preferred today. The circular saw cut is the next most common type of cut. A gang saw cut is only offered in isolated cases.

In addition to its absorbent character, the rough-sawn shuttering board has a rough and differently structured surface depending on the type of cut. Boards are produced from mature wood and feature structural differences (branches, grain) which can be found in the moisture absorption and thus, from a formwork point of view, in small dimensional changes and in partial grey tone differences. The rough surface gives the concrete that is initially in a liquid form and in particular the cement slurry an increased roughness effect.

Excessive mixing water can migrate to the surface area into the open formlining pores. Sanding, dragwater effects, etc. are prevented. The concrete turns a darker shade of grey. Rough-sawn board formwork, which is surface sealed for economic reasons (multiple use), loses its absorbent property and is classified as weak to non-absorbent formlining. The concrete surface will thus be lighter.

Through the sealing/coating of the board surface, slurring of the new boards with cement/lime slurry is eliminated.

■ Frequency of use

– (depending on surface requirements, release agent application and cleaning):

■ Uncoated

– up to 6 uses

■ Coated

– up to 10 uses

depending on surface requirements, possibly more.

Planned surface, also partially sanded

Planned surface, also partially sanded boards, result in – as architectural concrete – a visually inexpressive flat concrete surface structure.

The low degree of roughness carries the risk of dragwater formation, sedimentation and thus partial grey tone differences.

Otherwise, the same applies to rough-sawn boards.

■ **Frequency of use**

– (depending on surface requirements, release agent application and cleaning):

■ **Uncoated**

– up to 10 uses

■ **Coated**

– up to 20 uses

Surface mechanically processed

Planed boards are surface-processed, planed boards are normally surface-treated by brushing, sandblasting or flaming. In formwork construction, the brushed surface is significant. Through brushing, the soft early wood pieces are removed far more than late wood pieces from the surface of the board. The grain of the board surface receives a "third dimension". The structure depth can be adjusted through the amount of brushing carried out. The raw, uncoated surface is slightly absorbent and largely prevents sanding, dragwater effects or sedimentation.

The surface is architecturally effective and visually uniform. Otherwise, the same applies to rough-sawn boards.

■ **Frequency of use**

– (depending on surface requirements, release agent application, structure depth and cleaning),

■ **Uncoated**

– up to 5 uses

■ **Coated**

– up to 25 uses

Boarded panels

Boarded panels are boards assembled from individual boards. As a rule, the boarded panels have a finger joint at the front end in order to create an offset board joint when joining the panels together. Board widths, finger joint lengths, panel widths and lengths do vary depending on the supplier. The type of joint can in part be selected.

The board surface can be selected as rough-sawn, planed or brushed according to order requirements. The board panels are mainly coated (PUR lacquer, synthetic resin). This means no slurry-ing is required before the initial use and the surface is classified as non-absorbent.

Due to the production taking place in special manufacturing facilities together with many years of experience, good concrete quality and board moisture content is normally to be expected. A uniform concrete finish can be achieved with these boarded panels. With some types of boarded panels, the jointing system of the panels can cause the panel joint to be larger in width than the board joints due to swelling and shrinkage. This means that these joints are shown and visible in the concrete surface.



Boarded panel (sample with finger joints).

Otherwise, the same applies to boards.

■ **Frequency of use**

– (depending on surface requirements, release agent application and cleaning):

■ **Uncoated**

– up to 8 uses

■ **Coated**

– up to 25 uses

5 Formlining

5.3 Wood as formlining

Joint formation for boards and boarded panels

The impression of the formlining joint on the concrete surface is characterized by 2 factors:

- **Tightness of the formlining joint**
- **Tolerance of the formlining**
 - Manufacturing and cutting tolerance
 - Dimensional changes due to swelling and shrinkage

Tightness

The tightness of the joints is influenced by the constructive design as well as by the tolerances of the formlining. The type of joint selected depends on the requirements placed on the board joints.

- **The following are to be evaluated:**
 - Nib formation
 - Bleeding, sanding
 - Different board deflections

Joint formation for boards

With jointed boards, the joints are sealed against cement paste escaping. The choice of jointing should be left to the contractor because it has hardly any effects on the architectural concrete surface.

The important types of jointing and their assessment



Butt joint

Boards with no tongues or grooves = easiest method → formation of nibs, sanding, nests and much more are due to this type of jointing.



Triangular tongued and grooved joint

In terms of results, this joint is hardly better than the butt joint. This type of joint cannot be professionally recommended.



Rebated joint

With a proper moisture content, neither slight offsets nor nibs can be completely avoided. The boards can deflect slightly differently. Sanding, formation of nests etc., on the other hand, are not to be expected because the horizontal joint of the rebate is a proper seal.



Tongued and grooved joint

The most well-known and often used type of joint has the same appearance as the rebated joint, i.e. nibs and offsets are hardly avoidable, different board deflections can be avoided.



Disadvantages compared to rebated joint

- More time-consuming when assembling and dismantling
- When dismantling, the tongue usually breaks and cannot be used again.
- Use on curved surfaces only possible to a limited extent.



Wedge-shaped rebated joint (Z-profile)

This type of joint is the most suitable for use. The advantages of the above types of joints are all included here. This joint should be used to achieve a clean and uniform boarded architectural concrete surface.

Additional sealing by means of joint inserts (sealing strips) or pallet knife is not customary for boards.

Types of fastening for boards and boarded panels

As a rule, boards and boarded panels are fixed from the concrete side to the sub-construction.

The following fixing means are used:

- nails and screw nails
- staples
- screws

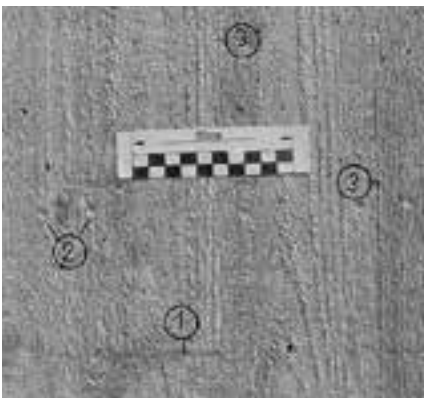

Concrete finish: Nails

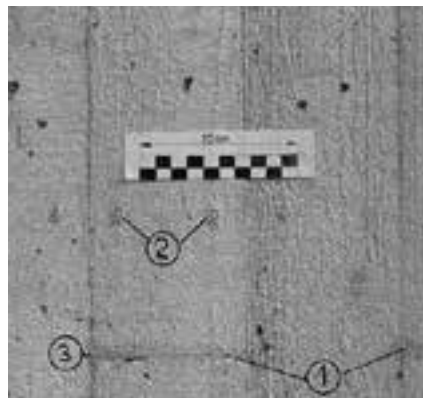

screws

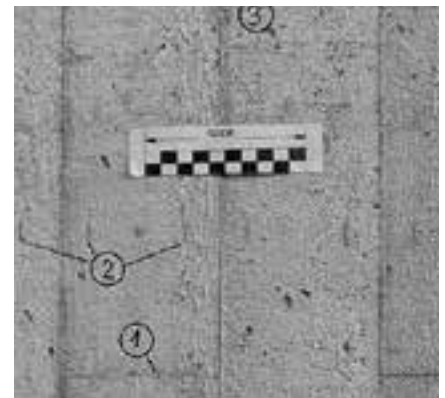

staples

These fixing points are visible on the board surface and thus on the concrete surface itself. Especially for meeting architectural concrete requirements, these fixing points are to be arranged in a neat and tidy grid pattern (formwork system-dependent). Nail and screw heads should protrude from the board surface (approx. 1 mm – 1.5 mm). The protrusion should only extend so

that no concrete slurry can run under the head. Otherwise, concrete cracks could occur when striking!

Due to the nail or screw head protrusion, this causes a clear imprint in the concrete surface which remains throughout the service life also if swelling occurs on the board. Countersunk screws and nails result in protruding "concrete warts" on the concrete

surface. Through the different wood strengths (early and late wood, branches), a uniform projection of the nails and screw heads cannot be guaranteed. Staples are invariably fixed slightly sunken to surface-flushed in the direction of the fibre. The impression in the board is enlarged during the first concreting cycle.

5 Formlining

5.4 Formlining boards

General

The finished concrete surface is primarily the mirror image of the formlining sheet that has been used. Selection of the formlining depends on the requirements placed on the concrete surface. For concrete surfaces without any special requirements regarding the surface quality, rental formwork is normally used. These are formwork systems (see Section 4), which are equipped with a film-coated formliner as standard. Due to the nature of the rental system, individual elements have different degrees of utilization. Any damage to the formlining itself is repaired correctly. The primary aim is to achieve a high number of repeat uses with low costs with the materials provided.

For concrete surfaces with surface quality requirements (= architectural concrete), the selection criteria for the formlining are different. Here, the expectations of the architect for the concrete surface are to be matched through the selection of the plywood with regard to surface quality, format, type of fixing and grid, joint arrangement and design. The formlining is chosen in accordance with the concrete surface requirements, frequency of use of the plywood, load, and the selected formwork system.

The following information should help when choosing the most appropriate plywood formliner. However, the range of different types of plywood is so large that it cannot be comprehensively presented here.

A distinction is made between the following basic types of formlining sheets:

- 3-ply plywood
- Veneered plywood sheet
- Blockboard or laminboard panel
- Wooden composite board (chipboard, OSB panels)
- All-plastic panel
- Metal sheeting

3-ply plywood

(3-ply plywood)

3-ply plywood panels consist of 3 layers of continuous boards. The outer layers have the same thickness. The middle layer must not be thicker than either of the two outer layers. The direction of the two outer layers also indicates the main bearing direction of the panel.

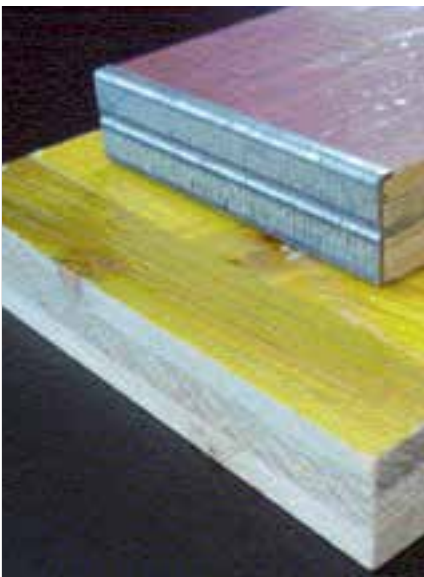

Standard panels

Size

Width: 50 cm
Length: 150 cm, 200 cm, 250 cm
Thickness: 21 mm, 27 mm

Surface

Uncoated or coated with synthetic resin (melamine resin).

Edge protection

Long sides coated with melamine resin as with the surface. End faces are usually fitted with a metal edge protector (galvanized E-profile) or secured by a concealed edge band.

Range of application:

Primarily for slab formwork without special surface requirements.



Large-sized 3-ply plywood sheets

Dimensions

Width: up to 3.00 m depending on the manufacturer

Length: up to 6.60 m depending on the manufacturer

Thickness: 21 mm, 27 mm or on request, depending on the manufacturer

Regarding the dimensions, the first length always indicates the direction of the cover layers. This is also the main load-bearing direction of the sheet.

Surface

Coating

Uncoated or coated with synthetic resin (melamine resin).

Structure

Rough-sawn, planed and sanded, structured (brushed with different structure depths).

Depending on the surface of the sheet, a different thickness of board structure always appears on the concrete surface.

Edge protection

Normally no special edge protection is required. For coated plywood sheets, the coating also extends over the edges during production at the factory.

In order to simulate a board structure on the concrete surface, additional V or U grooves can be milled at selected spacing (8 cm – 12 cm). U-grooves are preferred because the resulting concrete nibs have a higher stability, especially during striking.

The structure, coating and groove formation can be combined as required.

There are significant differences in quality between the individual providers regarding:

- Board width of the decking boards (50 mm – 250 mm)
- Uniformity of the middle layer
- Thickness of the individual board layers, edge layers always the same thickness (5 mm – 9 mm)
- Partial joint bonding of the cover and middle layer boards
- Butt-jointed or continuous boards of the cover layer per panel

Depending on the coating, the sheet can be classified as having weak to moderate absorbency. Uncoated panels should be neutralized like boards before their initial use. Due to the crosswise bonding, shrinkage in the longitudinal and transverse directions is around the same. The panel dimensions are mirrored on the concrete surface. The board image complete with the grain is visible on the concrete surface.

The sheets are normally butt-jointed. If tight joints are required, sealing strips must be inserted in the joints.

■ Frequency of use

- (depending on surface requirements, release agent application and cleaning):

■ Uncoated

- up to 8 uses

■ Coated

- up to 30 uses

5 Formlining

5.4 Formlining boards

Veneered plywood sheets

General

Veneered plywood sheets for concrete and reinforced concrete construction are standardized in DIN 68792: 2016-08.

Due to the large number of suppliers, different constructive design, different formats, the wood used, processing and bonding quality as well as the type and quality of the coating, a comprehensive statement is not possible. It is limited to the key information regarding the use of these sheets which follows below.

Veneered plywood consists of at least 3 veneer layers. The veneer layers are arranged with crossed grain direction. The bonding must ensure cohesion in all weather conditions throughout the service life. For example, boarding according to EN 314-2, utilisation class 3 (exterior) [formerly:

DIN 68705-2:2016-03 → BFU 100 = boil-proof and waterproof bonded or BS 6566: WBP (W = waterproof; B = boil-proof; P = tested)]

Sheet thicknesses

A distinction is made here as follows:

Thickness up to 12 mm

Facing formwork – sheets are not self-supporting and are mounted on a fixing board as facing plywood in order to achieve a specific concrete surface.

Thickness 15 – 30 mm

Self-supporting formlining which can be mounted directly on the supporting structure of the formwork system.

Possible bending radii of the formlining cannot be specified in general terms. These are dependent on the supporting direction of the sheet, sheet structure and sheet thickness, wood moisture content, mounting type, etc. They are determined according to the manufacturer's instructions or after preliminary tests.

Dimensions

Width

up to 3.00 m depending on the manufacturer

Length

up to 7.50 m depending on the manufacturer

Thickness

2 mm to 30 mm

Standard size

250 cm x 125 cm or
125 cm x 250 cm with 21 mm or
27 mm sheet thickness

Regarding the dimensions, the first number always indicates the direction of the face veneer. This is also the main load-bearing direction of the sheet. Large-sized sheets are produced by combining a number of smaller formats. There are two qualities:

- Pre-coated panels are scarf-jointed while the sheet joint remains visible as a line on the concrete surface.
- Raw sheeting is scarf-jointed, then calibrated (sanded) and film-coated. These sheets are visually seamless.

Sheet structure

The types of wood and veneer thicknesses can vary greatly. Deciduous and conifer as well as a range of tropical woods are used. Depending on the type of wood, the veneer thickness along with the properties of the sheets also vary.

It is also possible to combine veneers of different types of wood in one sheet. Due to this very different structure, a general statement about swelling and shrinkage behaviour as well as strength is not possible.

The specifications of the sheet manufacturer are to be taken into consideration here.

A significant proportion of the sheeting is imported from Finland. A distinction is made between the following plywood constructions:

- **Birch plywood**
 - All veneer layers are made of birch
- **Combination plywood**
 - The two outer veneers are made of birch; spruce and birch alternate in-between
- **Combi mirror plywood**
 - Birch face veneers, middle layers made of alternating spruce and birch
- **Twin plywood**
 - Birch face veneer, middle layers made of spruce
- **Spruce plywood**
 - All veneer layers made of spruce

For meeting special requirements, a special structure is possible.



Uncoated veneer sheets (raw plywood)

As a rule, the face veneer is sanded, and one side of the sheet has a higher quality (low number of knots, no imperfections). Imperfection on the rear side, partially filled/smoothed with filler. The quality of the face layers can vary greatly depending on the type and quality of the wood used.

Application: for subordinate concrete surfaces, compensations in system formwork and concrete surfaces realized with absorbent formwork. If dusting/sanding of the concrete surfaces is to be prevented, the sheets should be neutralized in the same way as boards before their initial use (cement slurry).

The wood grain of the face veneer is visible on the concrete surface.



Coated veneer sheets

The majority of veneer sheeting is used with a surface coating.

Phenolic resin as coating:

For this coating, phenol resin impregnated paper (glue film) or fibre fleece is pressed onto the raw sheet or together with this by means of pressure and heat. Depending on the surface structure of the press plates, the formlining surface can be glass-smooth through to a matt finish. The hardened cured phenolic resin adhesive coating has a reddish-brown colour which has no impact on the concrete surface. The colour of the resin coating can be changed by adding colour, lettering, etc.

For the film coating, a surface weight of 120 g/m² to approx. 300 g/m² is ideal.

For special applications (prefabricated parts industry), film coatings up to approx. 600 g/m² are possible; this can also be exceeded for embossed surface structures.

The manufacturer's instructions are to be taken into consideration here.

Film coatings of over 300 g/m² provide hardly any advantages for the concrete surface. The coating is less elastic due to the higher thickness.

Moisture penetration via nail holes or similar surface defects can cause the sheet to swell and lead to spalling of the film coating in this area.

For a coniferous wood face veneer and thinner film coating (120 g/m²), the wood structure of the face veneer may be slightly visible on the concrete surface.

In addition to the smooth film coating, coatings with surface structures are also possible. These structures,

coating thicknesses and achievable concrete surfaces vary for each manufacturer.

With regard to the achievable concrete surface, film-coated panels are classified as non-absorbent formlining.

5 Formlining

5.4 Formlining boards

Due to the concrete compaction, the water/cement value increases towards the surface of the formlining. Ultra-fine/fine parts, air and water pores collect on the formlining surface and become visible on the concrete surface.

The smooth, non-absorbent formlining surface causes slight sanding, dragwater effects, sedimentation, etc., which may be visible on the concrete surface.

These formlining surfaces result in a lighter grey tone of the concrete. Grey-tone shading and hence a negative impact on the uniformity may occur.



No-oil coating

This is a special coating which eliminates the use of a release agent for the initial use, and can then be significantly reduced. The special surface benefits the movement of the pores to the surface of the formlining during the compaction process. The concrete surface has fewer pores. The main application of this formlining is for those concrete surfaces where no release agent is permitted (e.g. food and beverage containers).



PERI Beto-S

Absorbent film coating (MDO coating).
(MDO = medium-density overlay)

By changing the ratio of paper/phenolic resin content to 2/3 paper content and 1/3 phenolic resin in the film, a so-called absorbent film coating can be realized (film weight approx. 400 g/m²). The absorbency level when using this sheet is low. Precise statements are not possible.

The porosity of the concrete surface can thereby be somewhat reduced.

The concrete surface has a matt and darker appearance.

Note: before initial use, treat MDO film 2x with release agent.

Recovery time (re-drying) between uses depends on the weather 36 – 72 h.

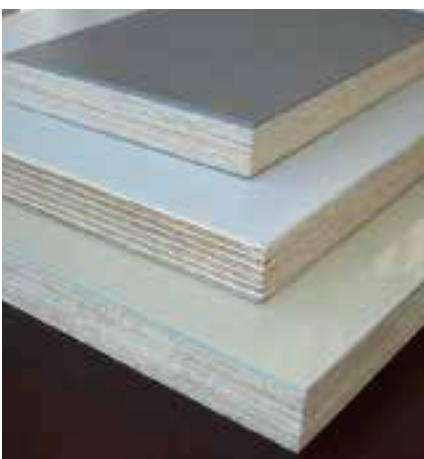

Polypropylene (PP), polyamide among others

In order to make the formlining surface more wear resistant, a number of new coatings are currently being developed, tested and piloted.

Based on previous experience, these coatings do not produce significantly different architectural concrete surfaces compared to concrete surfaces realized using phenolic resin surfaces. With coating thicknesses > approx. 1 mm, rippings are no longer visible as point or linear swellings. The wood core of the sheet then swells over a larger area.

Tolerances, moisture content, swelling and shrinkage of the sheets

According to DIN 68792: 2016-08 Issue date 2016-08 "Large-sized formlining sheets made of veneer plywood for concrete and reinforced concrete", the following tolerances are permissible:

Length and width:	± 3.0 mm
Sheet thickness	for 4 – 15 mm: + 0.2 mm to – 0.7 mm
	over 15 mm: + 0.2 mm to – 0.9 mm
Perpendicularity:	0.6 mm/m edge length

The values apply at the time of delivery of the sheets from the production facility. These tolerances can change significantly as a result of moisture absorption during transport, storage and use and must be added to the tolerances at the time of delivery from the factory.

Moisture content of the sheeting: the veneer plywood has an intrinsic moisture content of 5% to 9% due to the bonding process during production.

Through the non-absorbent phenolic resin film, a slight moisture exchange also takes place.

Self-supporting, film-coated sheets should have an intrinsic moisture content of 16% to 18% when used.

The sheets are then relatively dimensionally stable, i.e., weather or concrete-related stresses remain within the tolerance standard. Film-coated facing formwork sheeting, especially for curved applications, should have a higher intrinsic moisture content of 22% to 24%. Due to internal stresses, undulation may occur on these sheets. Uncoated panels should be used with an increased moisture level of approx. 18% to 20%. Through appropriate watering or intermediate drying, these moisture values are to be maintained as far as possible.

The sheets mainly have an edge coating provided at the production facility. Any cut edges and penetrations (anchor holes) should also be provided with an edge coating. These coatings (unfortunately often referred to as edge sealing) should hinder the penetration of moisture into the sheeting. Through these edges (end grain), the sheets absorb moisture more quickly than via the filmed-coated surfaces. In these areas, there is increased swelling – so-called rippling. This is particularly noticeable when using the sheets for the first time when the formlining has not yet reached the processing moisture content of 16% – 20%. With the uniform moisture penetration of the sheets in the subsequent operations, the ripples completely disappear.

Types of fixing

Normally, the formlining sheets are fixed from the concrete side to the sub-construction.

The following fixing means are used:

- rivets
- screws
- nails and screw nails

Concrete finish



Example of fixing: screwed



Example of fixing: nailed at the top, screwed at the bottom



Example of fixing: Nails



Example of fixing: staples

5 Formlining

5.4 Formlining boards

These fixing points are visible on the board surface. Especially for meeting architectural concrete requirements, these fixing points are to be arranged in a neat and tidy grid pattern (formwork system-dependent). Nail and

screw heads should protrude from the board surface (approx. 1 mm – 1.5 mm). This results in a clear impression in the concrete surface which remains throughout the service life also if swelling occurs on the plywood sheet.

Countersunk screws and nails result in protruding "concrete warts" on the concrete surface. If screws and nails are countersunk and filled, these areas can remain visible on the concrete.



Other sheet types: Blockboard or plywood sheets

Blockboards and boards with thin or thick laminations are standardized in the DIN 68791: 2016-08 Issue date 2016-08 "Large-sized formlining panels made of blockboards or boards with thin or thick laminations for concrete and reinforced concrete".

They are boards consisting of one or more veneers (arranged parallel to the grain or with a crossed grain structure) on each side and a middle layer of adjacent wooden strips (strip width approx. 24 mm - 30 mm). The strips of the middle layer can be bonded together. The veneer layers are to be bonded to each other and to the middle layer of strips so that cohesion is ensured in all weather conditions during the service life. Bonding according to EN 314-2 utilisation class 3 (exterior) [alt: DIN 68705-2:2016-03 → BFU 100 = boil-proof and waterproof bonded or BS 6566: WBP (W = waterproof; B = boil-proof; P = tested)]

Blockboards, whose centre strips are designated by arbitrarily extending growth rings, have low surface rippling as a result of different swelling of the centrally-positioned strips. This undulation effect is visible on the concrete surface and can lead to grey-tone differences.

Blockboards of thin or thick laminations differ from blockboard panels through the middle layer. The middle layer is comprised of up to 8 mm thick veneer strips which are stood on end and bonded together. This constructive uniformity of the middle layer ensures an optimum of flatness and consequently a high concrete surface quality.

Surface

Mostly film-coated as with plywood sheets

Load-bearing capacity

Due to the middle layer, the load-bearing capacity and deflection in both directions of the panels are very different and must be taken into account when supporting the panel (main and secondary support directions).

Otherwise, the same applies to blockboards of thin or thick laminations as for plywood sheets.

Used mainly in mould making and concrete formwork operations in the prefabricated component industry.

Wooden composite boards (chipboards, OSB panels)

As a rule, highly compressed chipboard is used as formlining. According to EN 312, the following chipboard types are suitable:

Chipboard type P5 =

boards for load-bearing applications in moist areas

Chipboard type P7 =

high-load boards for load-bearing applications in moist areas

Chipboards for formwork purposes should only be selected by manufacturers who have proven experience in the field of concrete formwork panel production.



According to the structure, a distinction is made between 3-layer and 5-layer chipboard whereby the top layer is produced with a higher binder content consisting of finer shavings and with very strong compaction compared to the coarser middle layers. 5-layer boards are additionally oiled on both sides. The panels should be V 100, i.e. boil-proof and waterproof-bonded. The water-resistant glue as a binder has no influence on the swelling behaviour of the wood chips and, in turn, the board. A special form of chipboard is the OSB board according to DIN EN 300: 2006-09: "Boards consisting of long, slender shavings" (OSB = Oriented Strand Boards).

As OSB boards, only those qualities according to DIN EN 300: 2006-09 should be selected:

- OSB 3 = boards for load-bearing applications in moist areas.
- OSB 4 = heavy-duty panels for load-bearing applications in moist areas.

Chipboard concrete formwork is available with a rough, oiled, treated and film-coated surface. Accordingly, this results in various fields of application, practical handling and efficiency appraisals. As formlining, raw chipboard is only significant for subordinate areas and create a structured surface. Individual chips can be incorporated into the concrete surface. Pre-oiled (factory), highly-compressed surfaces result in a structured concrete surface that has absorbent properties (darker concrete surface). However, absorbency decreases with increasing number of

applications (depending on the intermediate drying).

For film-coated surfaces, the same applies to plywood as for the concrete surface. According to the film coating thickness, the chipboard structure may be visible on the concrete surface. This is especially important for the coarser OSB board structure. Structured, especially resin-coated chipboard formwork have the technical advantage of creating "grippy" concrete surfaces with darker but uniform concrete surface effects.

Recommended moisture level for processing with regard to the strong swelling tendency of the boards: approx. 18% to 20% (manufacturer's moisture content approx. 5% to 13%)

Average frequency of use:

- **Rough-sawn surface**
– up to 4 uses
- **Oiled surface**
– up to 6 uses
- **Resin-coated surface**
– up to 8 uses
- **Film-coated surface**
– up to 12 uses



All-plastic panels for smooth concrete surfaces

Currently, only all-plastic panels with a 5-layer polypropylene sandwich construction have any relevance.

PERI SABO PLY

Example: design of a 21 mm thick panel

- 1st layer: Polypropylene film**
- 2nd layer: aluminium reinforcement**
- 3rd layer: foamed polypropylene core**
- 4th layer: aluminium reinforcement**
- 5th layer: Polypropylene**

For thin boards up to 15 mm, the aluminium reinforcement is replaced by crosswise-arranged glass fibre fabric.

5 Formlining

5.4 Formlining boards

The high price and the comparatively low number of applications for concrete surfaces with high architectural requirements do not allow their use in this area yet. An important advantage of these boards compared to wood-based composites is the insensitivity to moisture and thus ensuring absolute dimensional stability. Surface repairs can be carried out whilst leaving only minor visual traces on the concrete surface. The high coefficient of thermal expansion can lead to problems, however.

Textured formwork

Textured formwork is prefabricated (factory) and consists of formlining panels or matrices complete with a specified surface structure. They are self-supporting or can be attached to a load-bearing sub-construction. The possible surface structures are very versatile. The specialist suppliers have an extensive range of surface structures to choose from.

Special customer requests can be realized within the given framework. The main areas of application are in the prefabricated component industry.

The application recommendations of the individual providers must be observed.



Plywood panels with surface structures

This is surface-coated formlining. On one side, a structure is pressed into the thick film coating. As a structure, a wood structure with different profile depths is chosen.

The sheets are available as facing and self-supporting formlining. Due to the coating, this formlining is classified as non-absorbent. The achievable number of uses depends on the structure and coating used.

Fibre glass plastic formwork (GRP)

This is manually manufactured formwork units whose shape offers virtually unlimited possibilities. Depending on the design, a high number of applications (more than 100) can be achieved. Its use is limited to the prefabricated component sector. The high production costs require a correspondingly high number of applications so that low usage in-situ concrete construction is not relevant.

The formwork is classified as non-absorbent.

Polysulphide formwork

This is an elastic textured formwork with a predetermined design on the basis of an original model. Due to the elasticity, the formlining is fixed to girder formwork. The elasticity also allows striking of complicated forms.

The costs, number of repeat uses, structures, formats, processing instructions, etc. are to be agreed on with the manufacturers.

Polyvinyl chloride formwork (PVC)

PVC board material of different thicknesses is brought to a surface model template (matrix) by means of heat and absorbs this surface structure. Corresponding to the structure and material thickness, this formlining is self-supporting or is fixed to beam formwork. The material is rigid to flexible. The surface is non-absorbent.

The costs, number of repeat uses, structures, formats, processing instructions, etc. are to be agreed on with the manufacturers.



Polyurethane formwork

As before, manufactured as a rigid or flexible formwork. The quality can be configured by adapting the plastic formula. The application conditions must be agreed on with the manufacturers.

Rubber formwork

Material: polypropylene silicone rubber for structured architectural concrete surfaces, as before.



Polystyrene formwork

In contrast to the aforementioned types, this is an industrially prefabricated, foamed plastic formwork. These lightweight textured sheets of simple, inexpensive quality can be used without requiring any special surface treatment as so-called "single-use formwork" especially for in-situ concrete construction. The full surface of the textured sheets is to be mounted on a fixing board. With an additionally applied film on the surface, repeat usage (approx. 3 - 5 times) is possible. Further details such as costs, number of reuses, textures, formats, processing instructions, etc. are available from the manufacturers.

Metal formwork

Metal formlining is mainly used in system formwork with a high number of reuses.

The systems concerned are spatial, wall and column formwork. The cost-effectiveness is due to the high number of repeat uses. For steel system formwork, it is assumed that the functional technical requirements, e.g. painting or decorating units etc., be arranged with respect to the concrete surfaces being created.

The constructive "joins" that may occur here remain flat within the tolerance standard according to "surface finished" structural work requirements.

As an alternative to rigid steel system formwork, lightweight metal formwork is available, e.g. helically wound tubes in circular column areas or recess units for ribbed slabs or coffered ceilings.

The special application conditions must be agreed on with the respective manufacturers.

For steel formwork, particular attention must be paid to the problems of corrosion protection.

6 Constructive details in architectural concrete formwork construction

6.1 Fastening means

The special features of architectural concrete formwork will be discussed below on the basis of a number of selected details. The diversity available in this area makes it necessary to be selective.

Nail and screw heads should protrude from the formlining surface (approx. 1.0 – 1.5 mm). Due to the nail or screw

head projection, this causes a clear impression on the concrete surface which remains throughout the service life also if swelling occurs on the plywood sheet. Countersunk screws and nails result in protruding "concrete warts" on the concrete surface. Chipping off or sanding these concrete warts requires a high manual workload but nonetheless they still remain visible.

Due to the different wood strengths (type of wood, early or late wood, branches, moisture content), a uniform protrusion of the nails and screw heads cannot be guaranteed. Subsequent manual correction will not be successful and should be avoided.

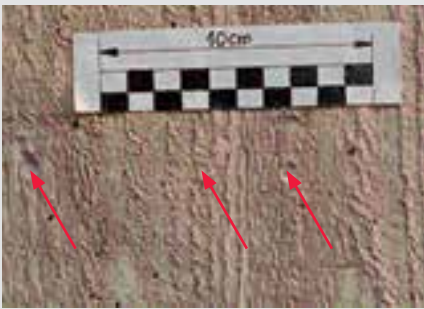

Nail head impressions in the concrete, here nails with oval heads.



Imprint of a nail head with a diamond pattern.



Fixing board formwork with staples. Impression of the staples on the concrete surface.

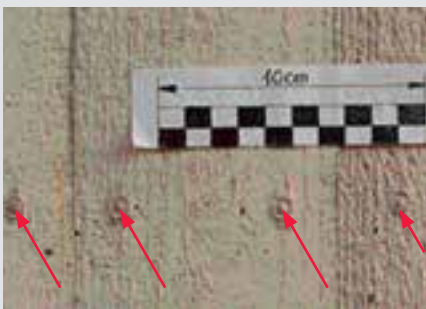

Fixing the formlining (here: boards) with countersunk screws.
Impression of the screw heads on the concrete surface.



Impression of the staples on the concrete surface.
Formlining:
smooth, film-coated plywood sheet.

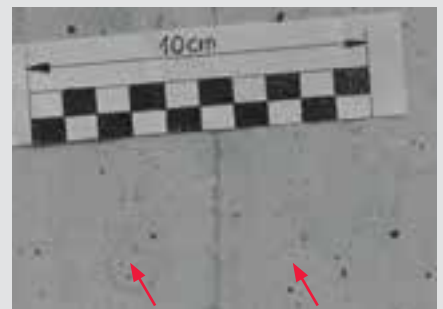

Formlining:
smooth, film-coated plywood sheet.

Screws:
countersunk, filled and sanded

In spite of this effort, the fixing points are still visible

6 Constructive details in architectural concrete formwork construction

6.2 Sealing the formwork

Sealing the formwork is indispensable for achieving a high-quality architectural concrete surface. With missing or inappropriate sealing, the concrete will "bleed".

At these places, porous, dark patches are formed that can be several centimetres wide. This greatly affects the aesthetic impression of an architectural concrete surface.

When choosing the sealing material, a distinction is made between joints that do not enlarge during concreting (sealed with "Tesamoll" or similar) and joints that increase during concreting due to the expansion of the formwork anchors (sealed with highly elastic material, e.g. sponge rubber).



Areas to be sealed:

Assembly area of the wall formwork on the slab / bottom slab

Sealing of girder formwork with a nailed/stapled plastic sealing cord Ø 20 mm.

Panel formwork likewise with sealing cord which is laid on the ground or with assembly foam. Sealing with Tesamoll or similar

Formlining joint in the panel Sealing with Tesamoll or similar

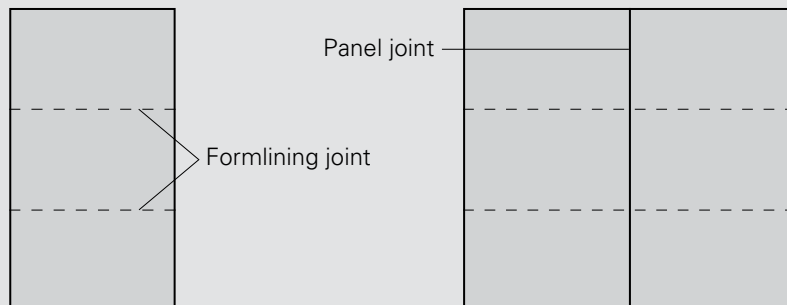

Formwork panel join

"Tesamoll" or similar can also be used here.

Alternatively, the vertical narrow side of a panel is coated with silicone. The next panel is then placed in the adjacent position, connected and aligned. On the concrete side, generously spray the silicone that has seeped out with a detergent solution and remove the fresh silicone with a plastic spatula.

Important: do not use silicone with absorbent formwork.

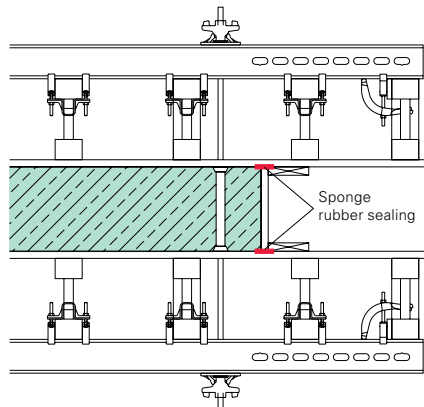

Stopend formwork, door and window recesses

Due to the elongation of the anchors during concreting, a small gap is created between the wall panel and stopend formwork or box-out which must be sealed.

Stopend formwork with continuous reinforcement

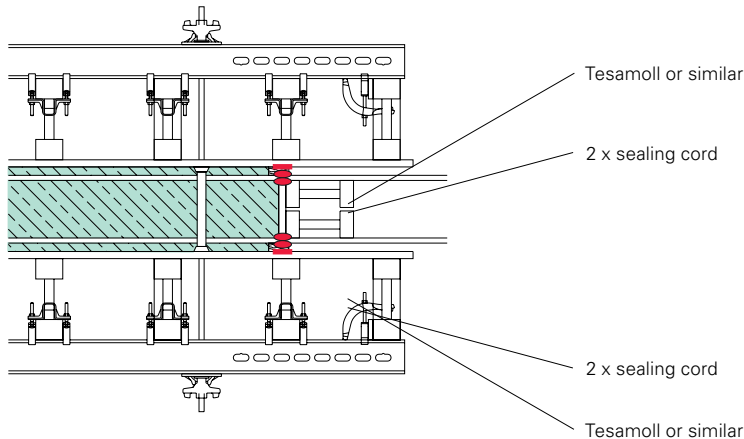

Sealing on construction joints

With these joints, a gap is created between the first casting segment and the pressed formwork caused by the elongation of the anchor when concreting the second casting segment. Therefore, a highly elastic material (e.g. sponge rubber) should be used for sealing.

The sealing tape should not be glued directly on the concrete as, after removing the tape, its adhesive normally still remains on the concrete and leaves a dark streak. Consequently, PVC construction duct tape is fitted between the concrete and sealing tape.

The top edge of the sealing tape and PVC construction duct tape should be flush after pressing the formwork panel. In order to achieve this, glue the sealing tape in its mounted condition 1 – 2 mm offset to the edge of the PVC tape.

This method can be used for both horizontal and vertical construction joints.

Alternatively, the exact position of the sealing tape is achieved by inserting it into a groove milled into the formlining. This allows the position of the sealing tape to be well monitored. The sealing tape should be significantly thicker than the depth of the groove. When pressing the formwork against the old concrete, the sealing tape disappears into the groove and can then expand out of the groove with increasing anchor elongation.

Joint between the slab formwork and wall

As walls in general are not completely aligned and cannot be realized with zero offset on the panel joint, this results in large joints to a greater or lesser extent when abutting the formwork panels or slab formwork elements against the wall. A "Tesamoll strip" is enough to seal the joints. If the width of the joint is larger, a 6 – 8 mm thick strip of sponge rubber is recommended. If the sealing strip is glued to the wall, as previously mentioned, first glue construction duct tape directly onto the concrete.

Tie points

See the next section.



6 Constructive details in architectural concrete formwork construction

6.3 Tie points with architectural concrete

With formwork anchors, the anchor elongation under load from the fresh concrete pressure must be taken into account. Pre-tensioning the anchors for the permissible anchor tension force is normally not possible because the spacer tubes of the anchors cannot accommodate these high pre-tensioning forces.

Anchor cone without lip seal

Due to anchor elongation, a joint is created between the cone and formlining surface. Leakage of ultrafine/fine particles can occur and cause the concrete to bleed around the tie hole.

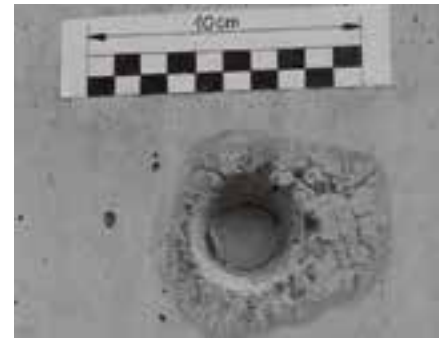

Anchor cone with lip seal

When tightening the tie rods, the cones are slightly compressed. During anchor elongation, this compression is reduced and the joint to the formlining remains sealed. The tie hole in the concrete is sharp-edged.

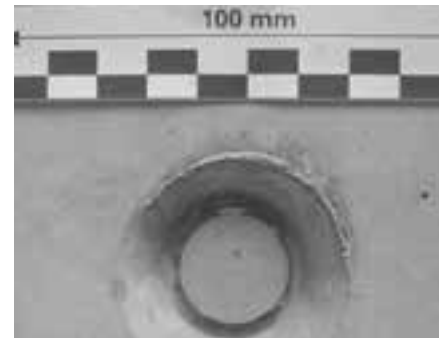

PERI DK Anchor Cone without additional sealing ring

As with the standard cone without lip seal, ultrafine/fine particles could escape from the anchor point due to anchor elongation.

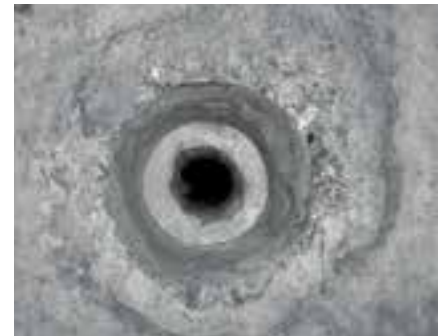



PERI DK Anchor Cone with an additional sealing ring (sponge rubber), a sharp-edged tie hole can be realized.



Sealing a tie point with offset formlining design element with a 4 mm thick sponge rubber ring on the PERI DK anchor cone.

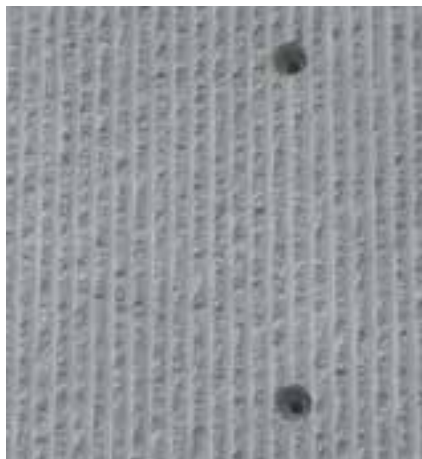

Closure of tie points constructed with DK and SK Anchor Cones.



Cone impression, unplugged



Plugged with silhouette cone



Plugged with flush-fitted concrete cone

6 Constructive details in architectural concrete formwork construction

6.3 Tie points with architectural concrete

Blind anchors for the design of a neat anchor pattern on the architectural concrete surface

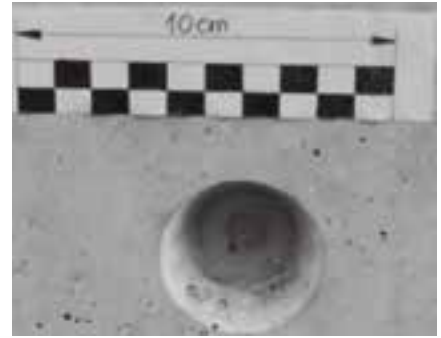

Climbing cones in an architectural concrete wall

Generally speaking, climbing cones leave a different visual impression in the concrete surface than anchor cones. PERI has therefore developed a system for climbing anchors whose openings can be sealed using the same DK Concrete Cones that are also used to close anchor openings.

- Platforms on one or both sides
- Closing anchor points with all DK Concrete Cones.

6 Constructive details in architectural concrete formwork construction

6.4 Joint formation in architectural concrete

Surface nibs on formlining and panel joints

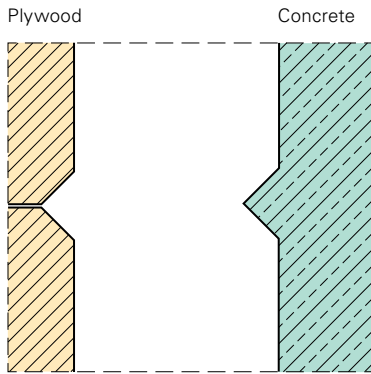

Seal-milled edges
Seal formlining joint



Forming construction joints in the wall

The preference of many architects is that the construction joints on the concrete surface are formed as a uniform line. Due to the known tolerance influences in the execution, this requirement can not be guaranteed.

In the following, a number of possibilities are shown which demonstrate how best to accommodate these requests with the formwork technology available.

Particular attention should be paid to the sealing of the joints; see Section 6.2, "Sealing Construction Joints".

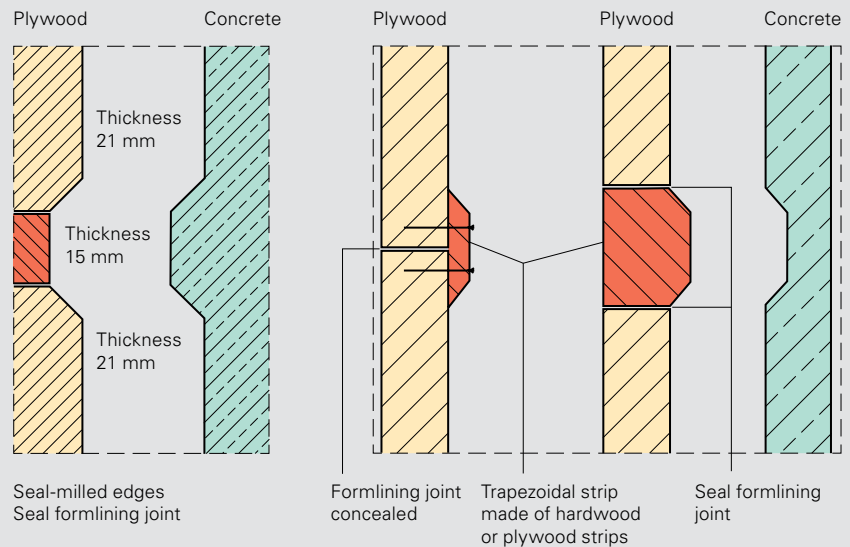

6 Constructive details in architectural concrete formwork construction

6.4 Joint formation in architectural concrete

1. Concreting section

For vertical joints, it is sufficient to insert a rectangular strip which is firmly attached to the formlining.

For horizontal joints, a trapezoidal cover strip is inserted and likewise firmly attached to the formlining. The trapezoidal cover strip has the advantage that the concrete completely flows under the strip and is neatly deaerated during compaction.

Rectangular or trapezoidal cover strips should be smoothly planed so that they are easier to remove when striking. This means broken edges can be avoided. A single coating on the strips means no water is absorbed and thus ensures that the adjacent concrete is not darkly discoloured.

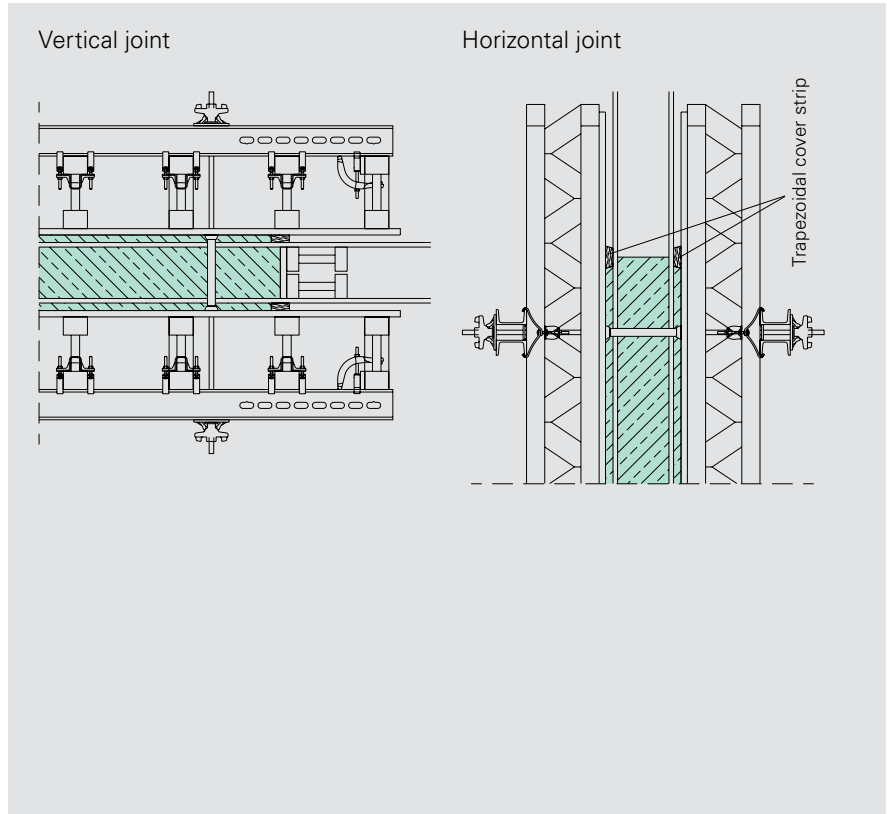

Second concreting section

After concreting the first section, the formwork is struck and the cover strips are likewise removed.

The formwork for the second section is pressed firmly against the first casting segment. For this, formwork anchors are installed close to the first casting segment or in the existing anchor holes of the first casting segment. These formwork anchors should be pre-tensioned as much as possible in order to counteract the anchor elongation during concreting. It is important to seal the joints as described in Section 6.2.

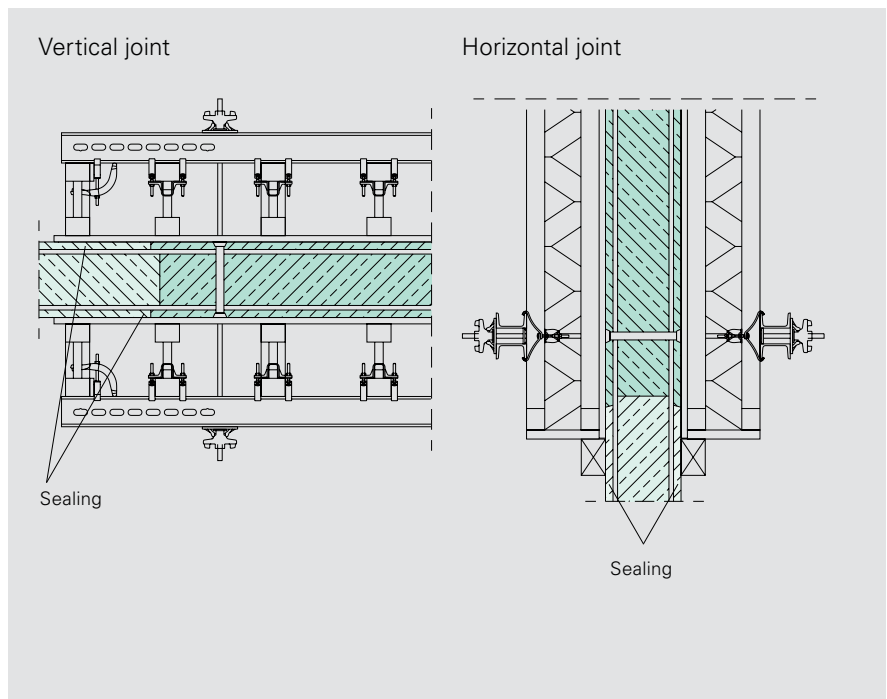

Pressing the formwork against the concrete

Tensioning of an additional VARIO Coupling through an anchor hole of the first casting segment

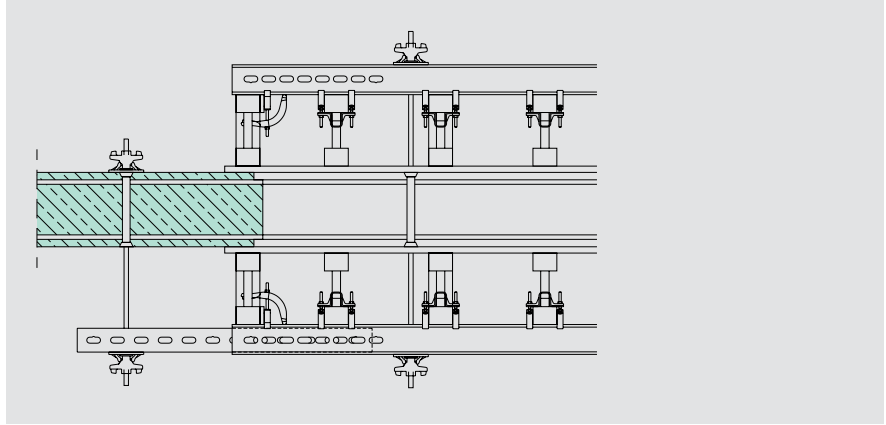

Hydraulic pre-tensioning of the anchors. Care must be taken to ensure that the clamping sleeves and plastic cones are not damaged. Generally speaking, the permissible anchor load cannot be applied. Very critical therefore is the pre-tensioning the clamping sleeves made of fibre cement.

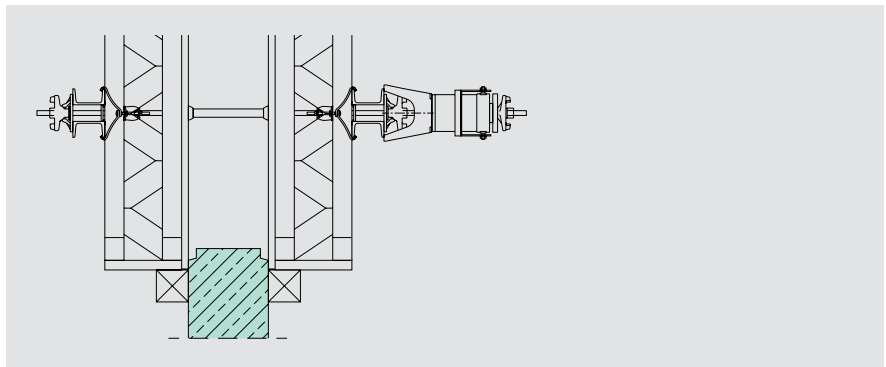

Forming construction joints in the wall/slab connection area

As a rule, the architect requests that only one construction joint visible on the outside in the area of the slab connection. The following images show the individual working steps for forming the construction joints.

This type of construction joint formation must be coordinated with the structural engineer.

Version 1

1. Concreting section

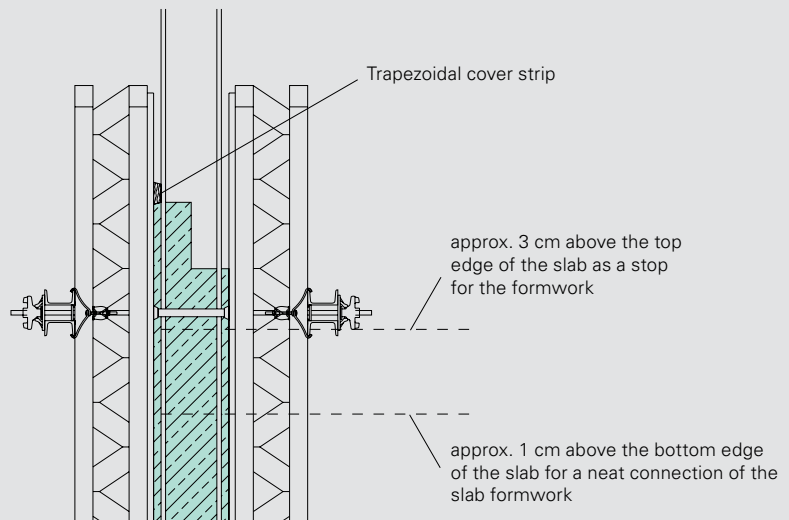

6 Constructive details in architectural concrete formwork construction

6.4 Joint formation in architectural concrete

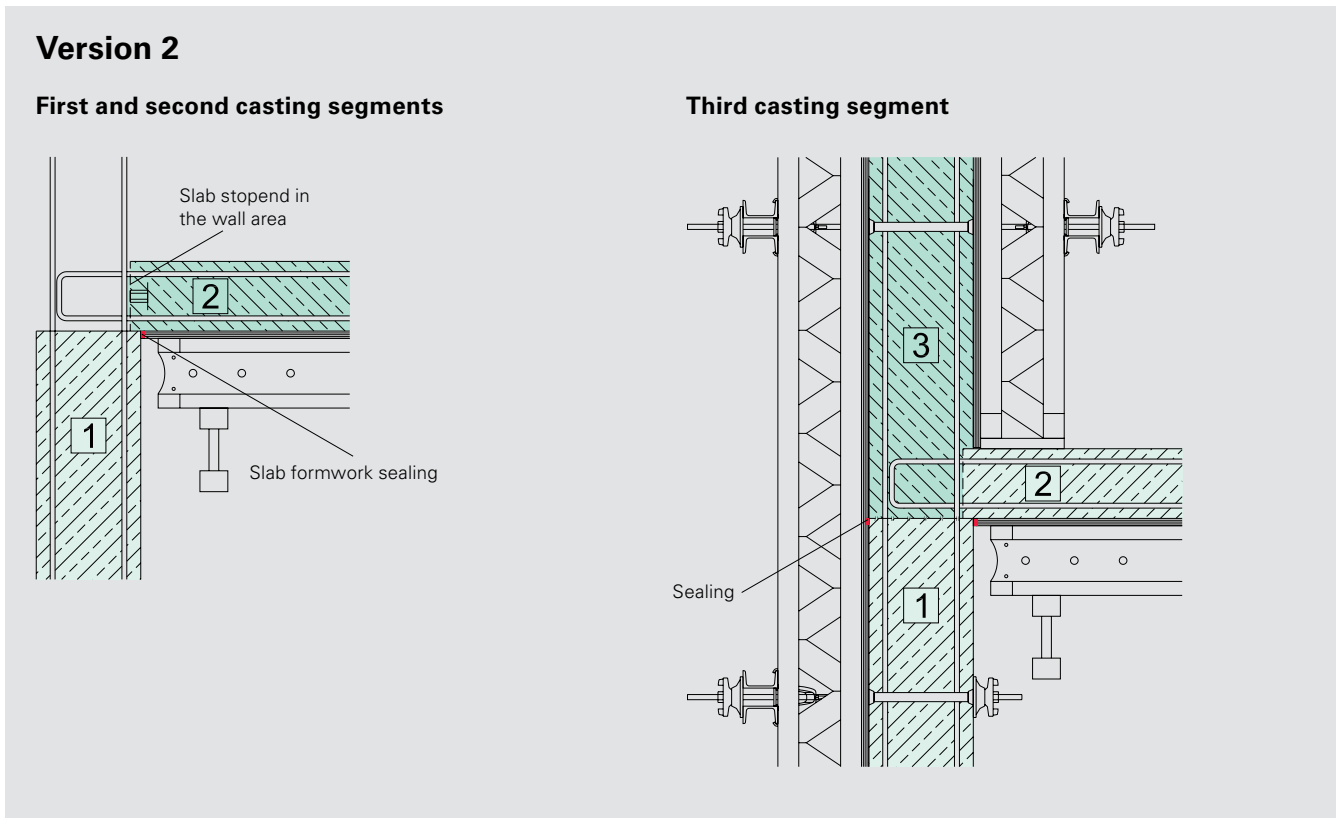
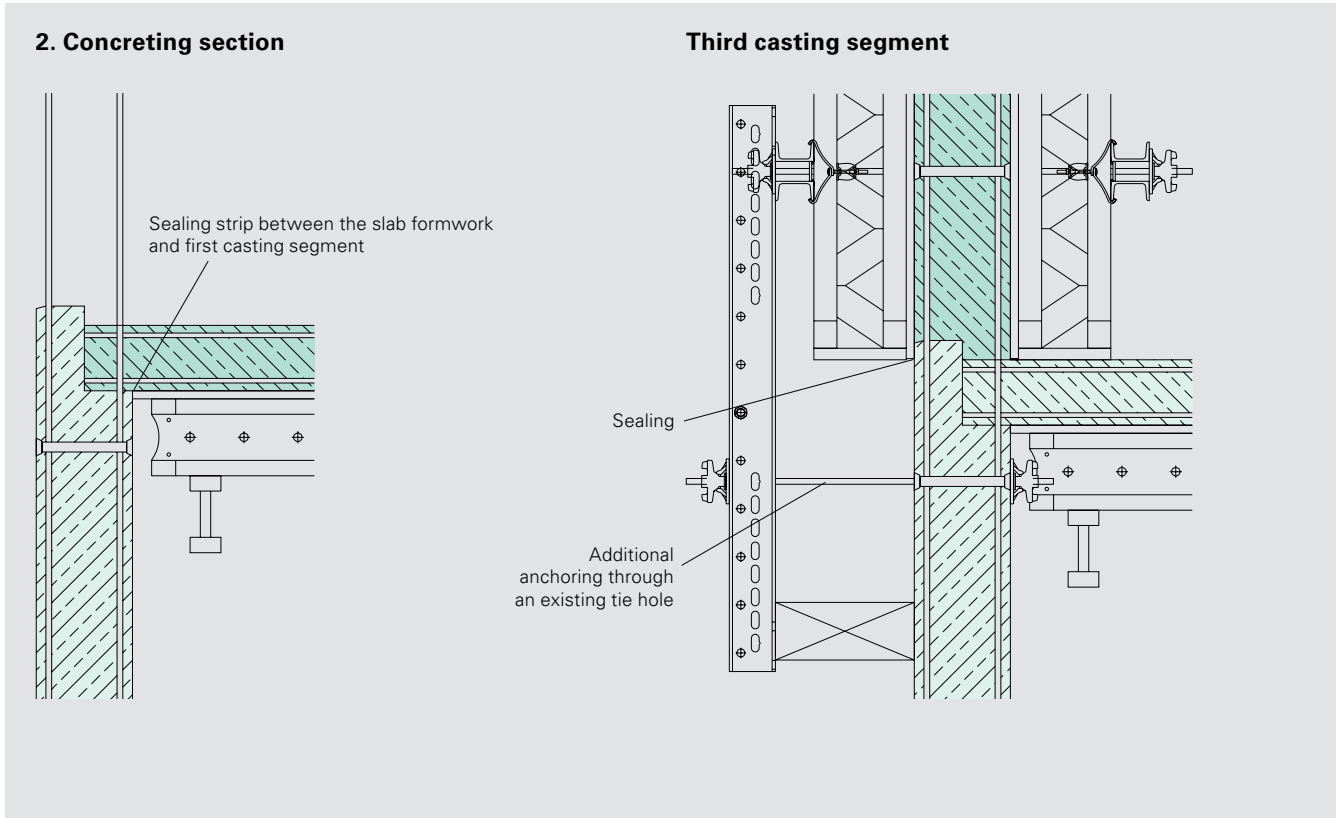

6 Constructive details in architectural concrete formwork construction

6.5 Formed concrete edges

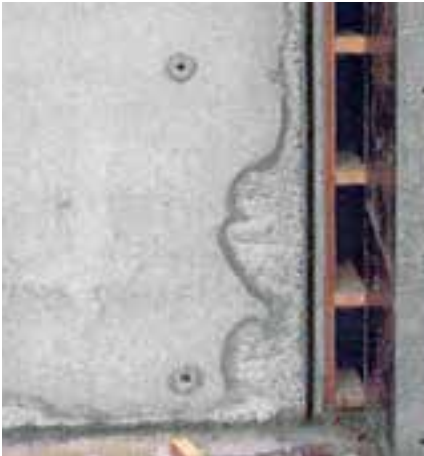

Bleeding on an external wall corner due to anchor elongation



Sharp-edged corner with bleeding as a result of slight leakage on the formlining joint



Wall corner with plastic chamfer strip, leg length 10 mm

Remaining concrete edges should be bevelled if possible with chamfer strips. A sharp-edged design cannot be guaranteed even with careful execution. Point 5) of the DBV Code of Practice is noted in section 5.1.3:

"The shape of the component to be constructed (height, thickness, mounting parts) must correspond to the technical requirements of concrete structure and allow the proper formation of edges and joints. For the planning and tendering of acute-angled walls, sharp corners, edges, etc. it should be noted that despite taking the greatest care in

specifying the striking time, edges can be broken also during the striking procedure itself."

Possible risks with sharp edges

- Corner is filled only with fine particles.
- With external components, the corner weathers the most.
- During use, the most vulnerable to damage.
- During striking, partial breakage of the edges cannot be prevented in spite of taking great care.

A chamfer strip is also a better guarantee for the tightness of the formwork.

6 Constructive details in architectural concrete formwork construction

6.5 Formed concrete edges



Attaching chamfer strips in box outs and stopend formwork

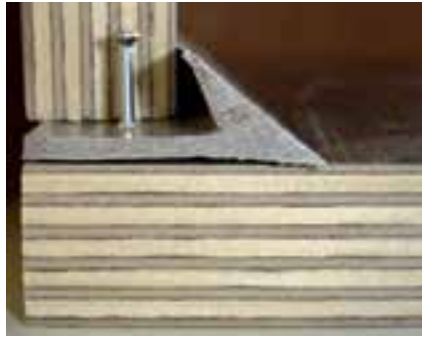

Plastic chamfer strip with nail flange



Wooden chamfer strip

Using chamfer strips

There is a choice between wooden and plastic chamfer strips.

For absorbent formlining surfaces (= uncoated boards or sheets), wooden chamfer strips are preferred because the chamfered edges are in the same

shade as adjacent concrete surfaces due to the absorbency of the strip.

For non-absorbent formlining surfaces (= coated boards and sheets) plastic chamfer strips are preferred as these, like the panels, are non-absorbent

and thus ensure that the same colour appears on all areas of the concrete. The plastic chamfer strips have the advantage that they have a nail flange and lip seal on the edges. As a result, they are concealed when nailed down and lie flush against the formlining.

Arrangement of the chamfer strips in box outs and stopend formwork.

Nail the chamfer strips on the formwork panels as they will slide slightly apart due to the anchor elongation during concreting; the chamfer strip will be "taken along" and continue to seal.

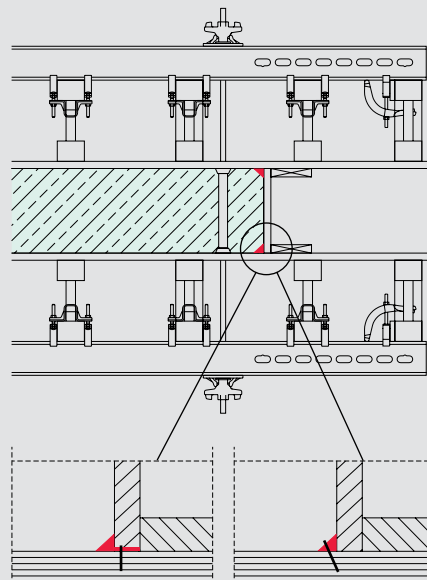

Plastic chamfer strip nailed to longitudinal formlining with nail flange

Wooden chamfer strip nailed to the longitudinal formlining



Here, the chamfer strip has been nailed to the stopend formwork. Due to the elongation of the anchors, a gap is created between the formlining and stopend formwork. The chamfer strip no longer seals. Ultrafine/ fine particles escape. (concrete bleeding)

6 Constructive details in architectural concrete formwork construction

6.6 Formed internal corners



Mitre joint with silicone grouting

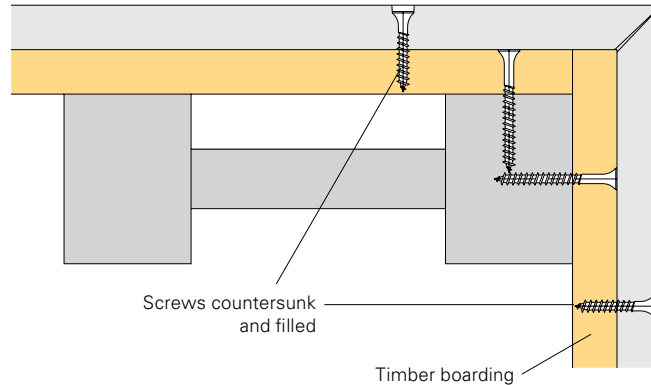

Mitre joint without silicone grouting

As a rule, architects do not accept any impressions created by the narrow side of the formlining on the concrete surface. In the area of the internal corner, the boards must therefore be mitred.

The following problems may occur: the film coating and veneer splinter; due to absorption of moisture, the formlining begins to warp with the result that the panel joint leaks (bleeding); during striking, the panel edge gets caught in the hardened concrete.

It therefore makes sense to have a 2 – 3 mm wide gap between the mitre-cut boards which is then grouted with silicone. This allows the panels to "work" while simultaneously sealing the cut surfaces.

7 Release agent

7.1 General requirements for release agents in regulations and codes of practice

DIN 1045-3:2012-03

DIN 1045 Part 3, Section 5.4 specifies the following requirements for the release agent:

- (1) Only release agents which do not damage the concrete, reinforcement or formwork may be used.
- (2) Release agents may not detrimentally affect the surface quality of the concrete.
- (3) The manufacturer's instructions for applying the release agent are to be applied.

DBV Code of Practice "Architectural Concrete" (06/2015)

For assessing a concrete surface, the DBV Code of Practice for Architectural Concrete states:

"The correct selection and application of the release agent is of great importance as the interface reaction between the formlining and concrete surface is significantly influenced by this. The release agent must always be used according to the manufacturer's instructions. The release agent film should be applied as thinly and evenly as possible, i.e. the applied quantity should be approx. 10 g/m² on non-absorbent formlining.

The release agent should dry quickly so that less dirt remains stuck to the formlining. Over-application or unsuitable release agents result in the formation of pores which leads to sanding and discolouration."

7 Release agent

7.2 Release agent requirements

The selection of the release agent depends on, in particular, the type of formlining used, manufacturing conditions for the concrete (e.g. heat-treated concrete), and the particular requirements for the structural component to be constructed (e.g. architectural concrete, drinking water tanks).

The selection of an appropriate release agent should be left to the contractor.

Unwanted side effects are, for example: Negative effects on the concrete surface

- Increased formation of spots and pores.
- Sanding, heavy dusting, disruptions in the hardening.
- Effects on the adhesion properties of subsequent building materials (e.g. plaster, adhesive, paints) through release agent residues.
- Slow weathering.
- Residual chemical effects.

Negative effects on the formwork

- Promotes rust on steel formwork.
- Swelling or buckling of timber formwork or coated timber materials.
- Etching of plastic formwork.

Note: some effects, regardless of the release agent used, may also occur due to other influencing factors (concrete composition, compaction, post-treatment). In this case, the release agent cannot prevent their occurrence.

Furthermore, release agents should:

- be easy and versatile to use,
- help to protect and preserve the formwork materials,
- allow better aeration of the plywood/concrete interface,
- taking into account the above-mentioned requirements as environmentally friendly as possible and posing no risk to health.

For use on the construction site, the release agents should:

- be applied as evenly and thinly as possible,
- dry quickly so that less dirt remains stuck to the formlining,
- be resistant to weathering and mechanical abrasion (accessibility).

7 Release agent

7.3 Effectiveness of the release agent

Physical separation effect

through hydrophobic properties of the base material. A water-repellent film reduces the contact between concrete and formlining.

Chemical-physical separation effect

– the physical separation effect described above is present in every release agent. Additional chemical separation is generally produced by fatty acids, which react with the alkaline components of the concrete (= "targeted hydration disruption").

Fatty acid + calcium hydroxide → lime soap + water

The lime soap in a thin surface layer also has a separating effect. Note: due to the targeted hydration disruption on the concrete surface, slight dusting is observed after striking.

Mineral oil-based release agent without chemical additives

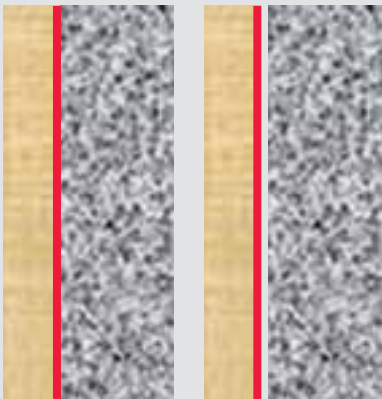

Only physical separation effect

Viscosity
Solvent-free release agents (mineral oils) have a higher viscosity and thus cannot be sprayed so thinly. Surplus release agent must therefore be removed.

Mineral oil-based release agent with chemical additives

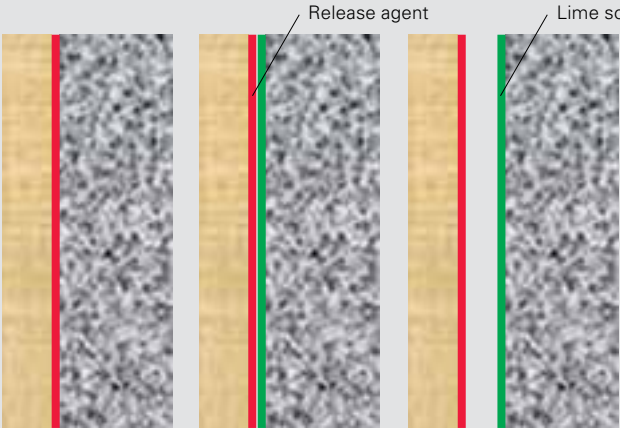

Additional chemical separation effect through the formation of "lime soap"

Solvent-based release agents have a low viscosity and can easily be sprayed on as a thin film. The solvent content of 50 – 80% evaporates thereby reducing the application thickness.

Solvent-based release agents are particularly suitable for non-absorbent formlining.

Aqueous release agent emulsion: The solvent was replaced by water and the mineral oil content by predominantly renewable raw materials.

The viscosity is very low and, after the water has evaporated, remains a very thin, rain-resistant film on the formwork.

Viscosity		
PERI Plasto Clean 9 mm ² /sec	PERI Clean 17 mm ² /sec	PERI Bio Clean 30 mm ² /sec

7 Release agent

7.4 Selection of the release agent

The requirements and operating conditions are decisive regarding the selection of the release agent.

Non-absorbent formlining = solvent-based release agent for thin applications.

Absorbent formlining = solvent-free release agent is more difficult to be absorbed into the formlining.

For architectural concrete, a quick drying release agent prevents the adhesion of dirt (e.g. rust, dust), and reduces the risk of slipping with slab formwork.

Low degree of stickiness benefits the ascension of air and water pores during compaction on vertical and inclined formwork.

Basically, sample concrete surfaces are constructed before each use of a release agent in order to verify the effectiveness and compatibility of the release agent with the formlining and concrete. For architectural concrete, this testing is absolutely essential.

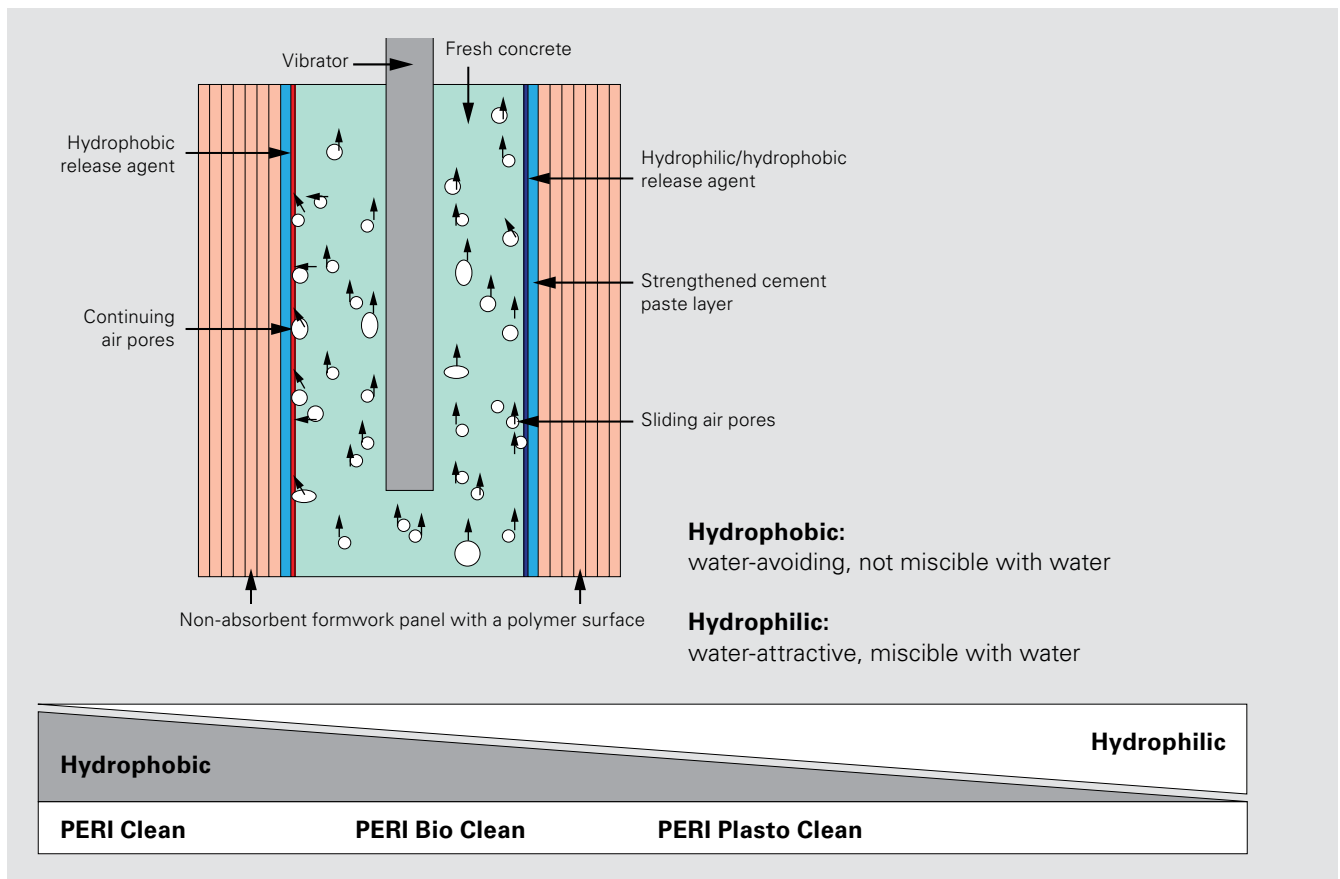

Caution when using aqueous release agent emulsions: the release agent must always be stored at temperatures above 0 °C.

Freezing makes the release agent unusable. Similarly, the formlining which is sprayed must have temperatures > 0 °C, otherwise the water contained in the release agent forms a thin layer of ice on the formlining which, in turn, prevents the separation effect.

7 Release agent

7.5 General instructions for the use of release agents

Apply release agent as thinly and evenly as possible to the carefully cleaned formlining but applied with sufficient separation effect. After applying the release agent, remove any surplus release agent with a rubber lip scraper or similar. After this, wipe with an absorbent cloth. This is especially recommended for non-absorbent formlining (film-coated sheets) for a uniform, thin application.



For natural wood surfaces, a uniformly thin release agent film is difficult to achieve due to the different absorption behaviours. Here, the wood surfaces should be wetted beforehand.

Optimal release agent quantity

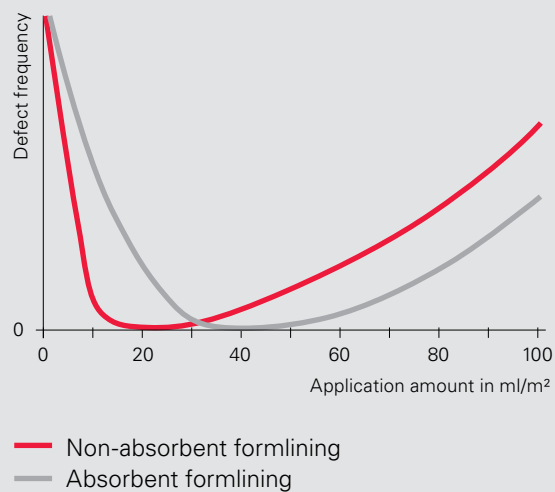

Determining the optimum amount of release agent by means of the finger test.



From the DBV Code of Practice –
"Architectural Concrete"

Prior to installation, treat the formlining with release agent so that the connection areas (concrete surfaces of the reinforcement connection) are not wetted and thus reducing their bonding strength.



Uniform, thin release agent application is not possible in this way.



A uniformly thin application on the formlining is recognizable by a matt gloss finish.



Over-application of the release agent can lead to dusting on the concrete surface, especially in the case of chemically-physically acting release agents due to "targeted hydration disruption". Slight dusting is typical of these release agents.

For architectural concrete surfaces, it should be noted that the mineral oil components of the release agent begin to oxidize (harden) at temperatures $> 50\text{ }^{\circ}\text{C}$.

In the process, the release agent turns a shade of brown.

Significantly higher temperatures can be created through intense sunlight on the darker film of the formlining and through the heat generated by hydration process in the concrete. This can lead to brown-coloured release agent patches on the concrete surface. With an increase in temperature, the viscosity of the release agent decreases and the release agent flows downwards. As a result, trace marks (release agent concentrations) can be seen on the concrete surface.

Too much release agent applied.

The release agent runs downwards due to the change in viscosity at high temperatures on the formwork.

Condensation water and release agent concentrate in the lower formwork area and can be seen on the concrete surface. Rust and dirt can intensify this.

8 Concreting capability and placing of concrete

8.1 Concreting capability of the concrete components

In order to achieve a good concrete surface quality that meets the requirements of the tender, the concrete component is to be designed so that the concrete can be properly placed and compacted. (Task of the planner)

The recommendations of the DBV Code of Practice "Concreting Capability of Concrete and Reinforced Concrete Components" must be strictly observed for architectural concrete components.

Basic principles

- Building component cross-sections are to be so dimensioned and the reinforcement so arranged so that the placing of the concrete is possible with the best possible complete compaction without separation.
- Formwork, reinforcement and mounting parts must not prevent the escape of air reaching the concrete surface through compaction.
- The execution plans contain details of openings in the concrete, vibrator holes and concrete cover.
- A reduction in the large aggregates and/or the use of flow concrete can be necessary for narrow cross-sections and where reinforcement is concentrated.
- This information is to be specified in the working drawings!



Concreting openings in the reinforcement

The concreting openings in the reinforcement are to be designed at least 4 cm larger than the diameter of the concrete placing tubes or hoses.

Accordingly, the minimum wall thickness of the building component, in addition to the static requirements is: \varnothing of the placing tube (hose) + 4 cm + Σ of the reinforcement \varnothing lying above + Σ of the concrete cover.

The spacing of the concreting openings, that are dependent on the building component sizes and the density of the reinforcement, should normally lie between 2.0 to 2.5 m. With closer reinforcement, e.g. at intersections of high beams and secondary beams, a smaller spacing of between 1.0 and 1.5 m is recommended. For slab-type building components approx. 0.5 m thick, with a close grid of upper reinforcement, vibrator holes are usually adequate as concreting openings.

Double reinforcement in the joint area

as well as mounting parts are to be taken into consideration. If necessary, any concerns regarding concreting capability must be reported.

Vibrator holes

According to DIN 1045-3: 2012-03 Part 3, Section 6.4, the reinforcement is to be so arranged that the internal vibrators can be introduced from all necessary sides. For estimating the spacing of the immersion points, there is the following rule of thumb:

spacing of vibrator immersion points for architectural concrete: $6 - 7 \times d$, with $d = \varnothing$ of the internal vibrator. For lightweight concrete, this spacing is to be reduced by half. For thin and heavily reinforced building components, the spacing of vibrator holes of around 25 cm is recommended. The width of the vibrator hole is 6 to 10 cm, preferably 10 cm so that so that the vibrator can avoid any contact with the reinforcement. If the vibrator touches the reinforcement, this then begins to vibrate.

Fine particles accumulate on the reinforcement which are subsequently visible on the concrete surface. The use of individual rod reinforcement is to be preferred to fabric reinforcement because vibrations are transferred so easily.

Fresh concrete – project management, manufacture and placing

Qualitatively good and, at the same time, aesthetically appealing architectural concrete can only be achieved if appropriately high demands are made on the mix, manufacture and placing of the concrete, and these are also fulfilled.

- The concrete should not have a tendency to bleed nor have too much adhesion.
- Concrete should be low shrinkage with low water content, a favourable particle distribution curve, and an adequately high mortar content.
- Use DIN 1045-3 Amendment 1:2013-07 for the maximum values of fine aggregates and sand.
- Cement affects the colour of the concrete. However, this is covered by differences in the water/cement ration (unchanged water/cement value of the mixing batches, no residual water in the transport mixer truck), waiting times between individual layers when placing, irregular and inadequate compaction.
- Typical grey shade through the use of Portland cement with increasing iron oxide content darker, with blast furnace cement lighter with increasing content of blast furnace sand.
- In order to minimize colour differences in the concrete, the cement should always come from the same cement plant and aggregates always from the of cement or change in the cement content leads to clearly recognizable colour shade differences on the finished building component.
- Concrete liquefiers or plasticizers reduce water requirements when using the concrete. Carry out preliminary tests to avoid unwanted colour differences.
- For flowable concrete (F4, F5, F6), adding stabilizers ensures the homogeneity of the mix during placing.
- Hard coal fly ash (f) can reduce the water requirements of the concrete but its use in architectural concrete is not without its problems.

According to the requirements, a suitable concrete is to be selected from the types of concrete of the ready-mix concrete supplier or design an appropriate concrete mix. For the concrete mix, attention should be paid to the following points:

8 Concreting capability and placing of concrete

8.2 Placing of concrete and compaction

An experienced concreting team is to be used for the production of architectural concrete, and which has to be properly briefed before work begins. Achieving the architectural concrete quality should be practised beforehand by the placing team on a subordinate part of the building. Large drop heights and concrete heaps when placing concrete lead to separation of the aggregates and leave numerous air bubbles. Drop height max. 1.5 m, otherwise use concrete pipes. It is recommended to immerse the hose of the concrete bucket, pump hose or concrete pipe into the previously poured layer.

It is recommended to place concrete in layers of < 0.50 m (for denser reinforcement < 0.30 m) in order to facilitate the escape of air bubbles.

The concrete is to be filled in the middle and not against the formwork. Never use an inclined discharge hopper.

It is not recommended to place the concrete from below into the formwork by means of concrete pipe sockets. This creates patchy concrete surfaces in the area of the concrete pipe sockets.

Concrete compaction according to DIN 4235-1:1978-12, parts 2 and 4, issue date 1978-12

Compacting concrete with vibrators
Compacting with immersion vibrators
Compacting in situ concrete with formwork vibrators

Practically speaking, air pores are still present in fresh concrete which has been compacted by vibrators. Such pores are also found occasionally on the formwork surface. Fresh concrete that is practically completely compacted generally contains a natural air pore content of approx. 1.5%.

Use of internal vibrators

The vibrator is to be quickly immersed in the concrete and, after a short time at the deepest point, slowly withdrawn upwards until the vibrator head is visible on the concrete surface. Then quickly pull the vibrator out of the concrete. The escape of any trapped air is facilitated by this method. Do not immerse the internal vibrator too close to the formwork surface and do not touch the reinforcement. Immerse the vibrator through the upper layer making sure to penetrate the previous layer of concrete, and keep the vibration process to a minimum.

In order to minimize the accumulation of air pores in the upper area of a wall, it is recommended to re-compact the crown of the wall approx. 15 – 30 minutes after concreting up to a depth of approx. 50 cm using a vibrator with a small head diameter (finger vibrator). Alternatively, or additionally, by tapping on the formwork with a hammer, air bubbles are forced upwards. In order to prevent damage to the formwork, it is recommended to fit vibrator heads with a rubber cap when concreting slabs.

Use of formwork vibrators

When used correctly, formwork vibrators can help to achieve very good architectural concrete surfaces. The number of vibrators to be activated at the same time, vibrator positions, and vibration duration depend on the component geometry, concrete consistency and type of formwork (girder formwork, panel formwork). In addition, tests should be carried out to see whether a better effect can be achieved using compressed air or electric vibrators.

Fix the vibrator so that a large area of the formwork is vibrated at the same time. Do not fix the vibrator directly to the formwork but to those formwork components on which the formlining is attached. It is recommended to set vertical formwork walls on rubber strips so that the vibrations are slightly reduced.

Furthermore, this measure also facilitates better sealing on the assembly area. The vibrator should only be operated when the formwork is filled with concrete slightly above the point where the vibrator is fixed.

If no experienced team is available for using the formwork vibrators, specialist firms (e.g. Mooser/Munich, Wacker/Munich) should be consulted. These companies also hire out formwork vibrators.

High building components that are quickly concreted, especially those concrete surfaces that remain visible, should subsequently be compacted with formwork vibrators or tapping the formwork with a hammer in order to remove islands of water that leave sandy streaks and air pores on the concrete surface.

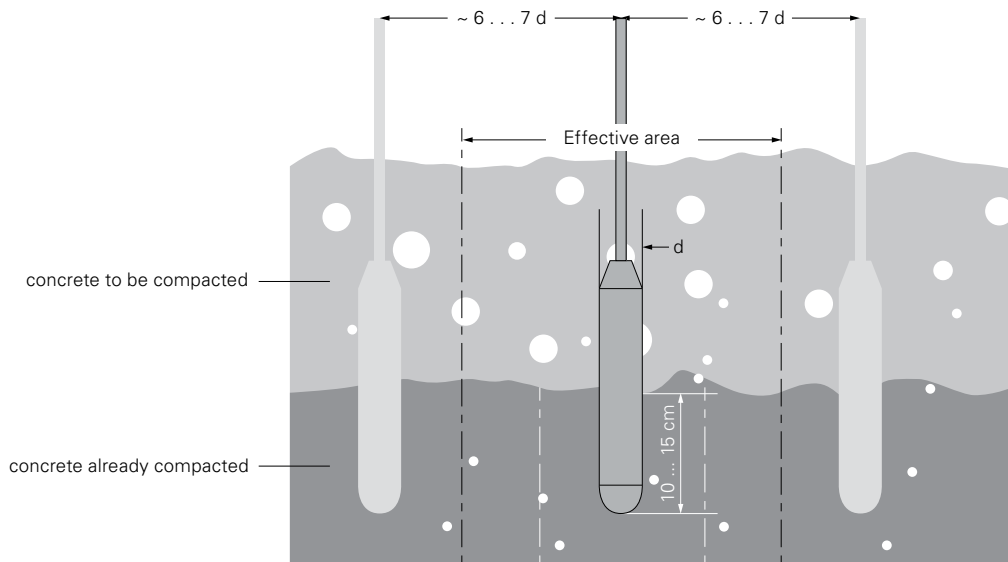

9 LCC + SCC and architectural concrete

9.1 General

- LCC: lightly-compacted concrete is standardized in the DIN EN 206: 2017-01 and DIN 1045-3 Correction 1: 2013-07 standards and is classified in Consistency Class F5 and F6.
 - SCC: self-compacting concrete has been referred to in DIN EN 206: 2017-01 since 2014. In addition, there is the DBV Code of Practice "Self-Compacting Concrete". SCC lies outside the consistency ranges of F1 to F6. Instead of the flow diameter, the slump flow with and without a J-ring and other test methods are used. SCC flows like honey.
 - The DBV Code of Practice SCC (12/2004) provides information on the manufacture and use of SCC. It complements currently available guidelines and general building inspectorate approvals to the effect of providing practical necessary information which is based on experience.
 - LCC is primarily used for horizontal building components such as bottom plates and slabs, steel fibre concrete, waterproof concrete and architectural concrete. Due to the high flowability of the fresh concrete, compaction work carried out when placing the concrete is reduced to a gentle vibration to poking. Concrete placing can take place at the top directly from the truck mixer, using a crane bucket or pump.
 - SCC is characterized by the fact that it flows independently without any external compaction energy effects under the influence of gravity almost to the level compensation point, de-aerates as well as completely fills the reinforcement cavities and formwork.
- Technical and economic advantages of SCC**
- Staff and equipment-related savings for compacting operations.
 - Shortened construction time due to a higher concrete placing performance.
 - Low noise level on the construction site.
 - Improved concrete texture and therefore improved durability.
 - This is set against higher material costs for the concrete, higher preparation costs, production and monitoring of the concrete.
Use only at $+10\text{ °C} < T < 25\text{ °C}$.
- LCC and SCC production requires extreme uniformity of the source materials.**
- Cement (also the same type of cement) exhibits fluctuations.
 - Aggregates with particularly features in the sand, especially the intrinsic moisture, as lightly-compacted and self-compacting concrete are particularly susceptible here.
 - Maintain the water-cement value, i.e. continuously monitor the intrinsic moisture content of the aggregates.
- The interaction of the powder materials and the admixture determine the workability period. It is strongly influenced by the reactivity of the cement, solution composition after adding water as well as the temperature.
 - Structures with more reinforcement require a SCC with a higher proportion of paste and an optimized grading curve in order to avoid blocking by coarse aggregates.
Note: larger aggregate size does not always mean higher strength.
 - Greater care in the planning, production and processing is necessary. This greater care and attention is also required for F5 and F6 concretes. Through the assistance of qualified concrete technologists, engineering control in the production of LCC and SCC is ensured.

SCC areas of application

- For architectural concrete components and building components with particularly difficult geometrical dimensions.
- For architectural concrete surfaces with high design requirements.
- For slender building components whereby appropriate concrete placing and/or uniform and sufficient compaction in vibrated concrete is hardly possible.
- For a particularly dense reinforcement layer.
- For difficult formwork technologies.
- For concrete surfaces with high technical requirements.
- For a necessary reduction of disruptive noise and vibration disturbance.

SCC performance capabilities

- Complete filling of the formwork and enclosure of the reinforcement.
- Uniform homogeneity of the concrete in the core and edge areas.
- Concreting capability of filigree elements and building components with high reinforcement content.
- Pore and blowhole-free concrete surfaces.
- High architectural concrete quality (Colour and surface texture uniformity).
- More robust against concreting errors than standard concrete.
- Cost-effective fields of application.
- Simple casting sequence.

9 LCC + SCC and architectural concrete

9.2 Fresh concrete pressure

Load from fresh concrete pressure for LCC

DIN 18218: 2010-01 "Fresh concrete pressure on vertical formwork" includes concrete up to a flow diameter of 600 mm (= F1 to F4). The fresh concrete pressure is determined in the new version of DIN 18218: 2010-01, Issue date 2010-01 by the different ends of setting (5 – 20 h).

Load from fresh concrete pressure for SCC (according to DBV Code of Practice SSC)

"For the planning and dimensioning of formwork for self-compacting concrete, it is recommended from a practical point of view to apply at least the full hydrostatic pressure even if it is not always achieved when placing self-compacting concrete because the knowledge available regarding formwork pressure-reducing influences from the thixotropy of the self-compacting concrete and wall friction has not been sufficiently researched and verified."

"If, on the other hand, self-compacting concrete is placed from below under pressure by means of concrete pipe sockets, it can be assumed that full hydrostatic pressure will always be achieved plus the usual addition for the pump pressure (approx. 25%)."

9 LCC + SCC and architectural concrete

9.3 Special requirements of SCC on the formwork

Joints

- Additional sealing of the panel joints is not required.
- Joint gaps of 2 – 3 mm are bridged by the concrete. For larger joint widths, the concrete will permanently flow out if there is no seal.
- SCC demonstrates a high cohesive capacity.
- The risk of bleeding at the tie points, corners and panel joints is less than with vibrated concrete.

The formwork shown is standard in vibrated concrete and unproblematic. For SCC, and possibly for LCC, the joint must be sealed at the bottom plate offset so that no pressure difference in the fresh concrete lateral pressure can accumulate, or the formwork is additionally tensioned on the bottom plate in order to transfer the additional compressive forces.

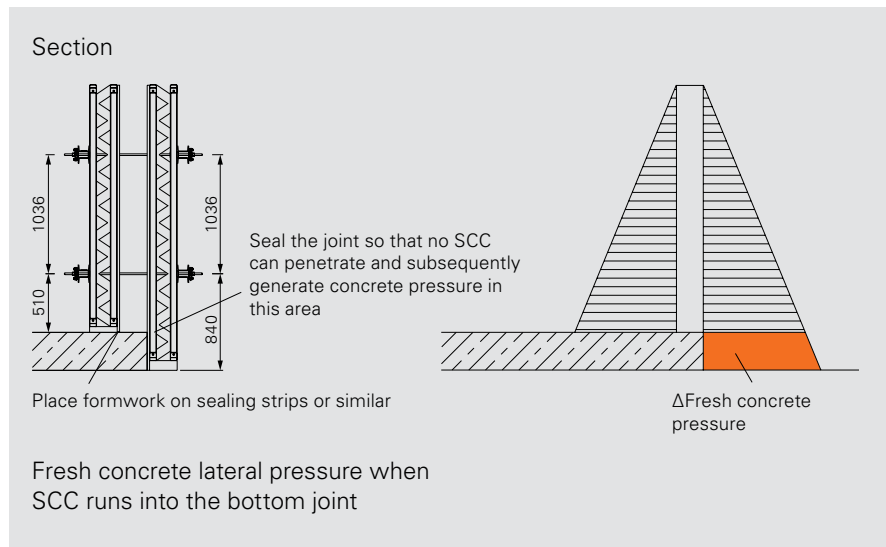

Upthrust

- SCC flows under box outs and slab formwork and over the entire surface. Full hydrostatic pressure occurs as upthrust.
- By means of appropriate measures (anchoring, ballast), these forces are absorbed and transferred.
- Note: Note: Additionally seal the formwork on the ground contact area so that no SCC can flow under and generate upthrust.
- Inclined concrete surfaces – due to the flow behaviour, inclined concrete surfaces can be realized only with cover formwork even for the slightest inclinations (approx. 1%). For cover formwork, the above applies (upthrust protection). The cover formwork must be mounted over the entire surface. For large horizontal or slightly inclined cover formwork, deaeration must be provided (small holes, filter fleece, or similar).

Stopends

- Tightly and immovably install the stopend formwork whilst taking into account possible anchor elongations, increased fresh concrete lateral pressure, etc.
- For expanded metal as formlining, a suitability test must be carried out with the respective concrete so that the concrete does not flow through the meshes.

Concrete pouring point

Standard concrete is normally placed and compacted layer by layer in the formwork. The formwork is calculated to accommodate the full filling level. Intermediate filling levels are hardly taken into account for the load assumptions.

SCC is poured into the formwork at one point (seldom at several points simultaneously) and flows from here throughout the entire formwork until it reaches the planned concreting height.

The concrete should flow over a longer distance in order to allow air to escape. As a result of this flowing action, filling conditions can occur on the formwork (door openings, corner areas, curved wall areas, etc.), which could lead to displacement, deformation, etc. of the formwork. Therefore, the pouring point for SCC must be agreed on between the concrete technologist and formwork planner. Based on this, the forces acting on the formwork (longitudinal forces) in all filling states are to be recorded with necessary additional support measures being subsequently provided.

10 Assessment, acceptance, defects

10.1 Assessment and acceptance

For assessing a concrete surface, the DBV Code of Practice Architectural Concrete, Section 7 states:

"The overall impression of a visible area is the basic acceptance criterion for the agreed class of architectural concrete. It should be noted that each building component is to be assessed as a unique piece (weather, delivery situation, etc.). Minor irregularities, e.g. texture and colour shade are characteristic in all classes of architectural concrete."

The architectural concrete classes in the code of practice are primarily defined using individual criteria. The assessment aims to assess the effectiveness through the compliance with individual criteria. This, however, is not in line with the construction method and contradicts the intent of the Code of Practice "Architectural Concrete". M. D. Peck observed in Concrete Information Special 4.05:

"Concentrating solely on the individual criteria can lead to the fact that architectural concrete surfaces, which correspond to the ideas of the planner due to a successful overall impression, nevertheless have to be rejected because of the failure of individual classification criteria. The overall impression of a visible area cannot be defined simply by listing the fulfilled individual criteria. For the planner, the overall impression of a surface is a central criterion and the only possibility to compare the finished object with his expectation. From this comparison, only the understanding of the processing that has taken place is ultimately useful. If the overall impression corresponds to the planning concept, the work is to be accepted and assessing the individual criteria is not required. Only when the overall impression of a surface fails to satisfy the contractually fixed notion of the planner can the individual criteria of the architectural concrete classes be used for further evaluation."

The overall impression of visible areas is assessed from a suitable viewing distance and in normal daylight conditions. The following viewing distances have been proven in practice:

Building structure

"The appropriate distance corresponds to the distance that allows the structure's significant elements to be optically realized. In the process, the decisive design features must be recognizable."

Component

"The appropriate viewing distance is the one taken by the viewer during normal use."

In addition to the viewing distance, the age of the assessed area is of crucial importance.

The fresh concrete changes its appearance over time (colour variations, dark-light stains).

The surfaces should therefore be as dry as possible.

10 Assessment, acceptance, defects

10.2 Defects



Refusal of acceptance

"From a legal point of view, refusal of acceptance (VOB/B Verdingungsordnung für Bauleistungen/Terms and Conditions of Construction Works, Section 12 (3) and German Civil Code Section 640 (1) is only possible in the case of material defects. It is therefore in the interest of all parties involved to individually determine that which is considered by the client to be a significant structure-related defect. The basis of the assessment is the overall impression of the respective building component or structure." A collection and assessment of architectural concrete defects is included in the book "Architectural Concrete Defects". (see illustration)

10 Assessment, acceptance, defects

10.3 Presentation of some typical defects



Dark discoloration on the plywood sheet/panel joint and the tie points. These areas are not sealed.



Bleeding in the area of the cone.
Anchor not properly tensioned or non-elastic sealing rubber.



Air bubbles under the height indicating strip.
Underside of the height indicating strip not chamfered.



Bleeding in the corner area and dark discoloration.
Wooden chamfer strip and nailed to stopend formwork.



Light/dark discolouration of the concrete.
The light area was covered during interim storage, the dark area exposed to the sun.



Visible "continuous spacer".
"Continuous spacer" laid with flat side on formwork.



Dark discolouration on a slab soffit.
Separating layer for slab prop made of wood materials or wood. Exchange of moisture between concrete and separating layer. Better to wrap the separating layer with geo-textile or foil.



10 Assessment, acceptance, defects

10.3 Presentation of some typical defects



Edge protection directly on fresh concrete.
Results in dark streaks on the corner of the
concrete surface.



Air pores in the upper wall area.
Post-compaction not carried out.



Wall reinforcement showing through.
Prolonged contact of the internal vibrator
with the reinforcement.



Rust streaks.
No protection of the connecting reinforcement.



Brown/yellow discolouration.
Condensation water with release agent residues.



Lower half of the wall is darker than the upper half. Below: increased depositing of calcium on the concrete surface. This results in a thicker joint and thus in a darker appearance.

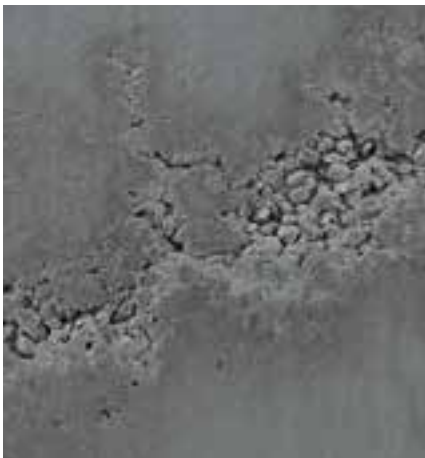

Water stains on the concrete surface.
Concrete bleeding heavily.



Aggregate nest.
Incorrect vibrator handling.

The following always applies:

- Keep the formlining clean.
- Avoid scratches → Overshoes made of felt.
- Do not place circular table saws on the slab formwork.
- No pencil marks, chalk lines, no inscribing of the formwork and finished concrete surface.

Remedial measure

- Lower water/cement value (<0.53)
- Robust concrete with good water retention capacity; among others, cement with high grinding fineness
- Soft consistency > F3, placed with very little vibration energy
- Cement with fast strength development
- CEM II cement with limestone meal, e.g. CEM II/A-LL, CEM II/A-M (V-LL), CEM II/B-M (S-LL)
- Increased fresh concrete temperatures in winter
- Supply of warm air
- Heating the formwork
- Fast striking (15 kN/mm²) and aerate
- No adjacent post-treatment measures
- Absorbent formwork, if possible

11 Architectural concrete working instructions for the construction site

Basic principles

All contractually agreed and binding project documents for architectural concrete (drawings, preliminary remarks, ZTV, etc.).

Execution of forming operations

For executing the shuttering work, the formwork plans released by PERI and checked by the site management, among others, provide the binding basis.

The general application conditions of the formwork are featured in the brochures, instructions for assembly and use, posters and operating instructions of the respective formwork system, and are to be taken into consideration.

The site management must prepare a set of assembly instructions on the basis of accident prevention regulations (Germany: UVV) as well as the instructions for assembly and use of the formwork systems used while also taking into consideration site conditions, and then notify the contractor. With forming operations for architectural concrete surfaces, suitable specialist personnel are to be used who are familiar with the formwork systems and the associated work documents.

Checklist: implementation instructions for architectural concrete forming operations

Work instructions	Measures/controls
<p>General information - formwork system: Panel formwork: used/new formlining matching the specified panel grid and tie arrangement. Girder formwork: panel size, formlining dimensions and joints, tie arrangement, architectural concrete coupling.</p>	
<p>Formlining: Type of surface (smooth, absorbent, ...) according to the invitation to tender; take into consideration the possible frequency of use during selection. Non-absorbent (smooth) formlining results in a light surface, absorbent formlining results in a darker surface. Formlining screwed on at the front = screw impressions visible. Formwork screwed on at the rear = no screw impressions, open formwork required. Filled screw heads are also visible on the concrete. For slab formwork with non-absorbent formlining, use new formlining if possible. Rust falling from the reinforcement does not then stick so much to the formlining surface.</p>	
<p>Checking the formwork plans with the project drawings that were binding at the time of execution.</p>	<p>Responsible: Site manager. Clarify differences with the formwork supervisor and formwork project manager.</p>
<p>Visual inspection of the delivered formwork materials regarding completeness, accuracy, quality, dimensional stability. Particular attention should be paid to any damage to the formlining/forming sections which could then be visible on the concrete surface.</p>	<p>Responsible: Site foreperson. Immediately report damage / complaints to the formwork supplier and jointly determine measures to be taken.</p>
<p>Clean the formwork of dirt before use.</p>	<p>Inspection: Site foreperson.</p>
<p>Correctly treat the formwork with a release agent.</p>	<p>Inspection: Site foreperson.</p>

Work instructions	Measures/controls
-------------------	-------------------

General information - release agent:

For a thin, even application, remove any surplus release agent using a rubber scraper and then wipe with an absorbent cloth.
 Keep the time between application and concreting short in order to prevent resinification of the release agent, especially in warm weather.
 If necessary, use a solvent-based release agent for thin applications.
 Test the behaviour of the release agent / formwork / concrete combination; price of the release agent is not decisive.

Assembly of the formwork by means of the intended assembly aids and sequence is carried out carefully in order to prevent any damage to the elements. Joint pattern: Observe tolerances. Basis: Assembly instructions.	Inspection: Site foreperson.
--	------------------------------

Primary formwork is installed first for formwork surfaces with increased requirements in order to be able to assess the quality of the surfaces and correct if necessary. Compliance with the exact dimensions and position of the forming area (perpendicular position), joint arrangement and formation, check assembly tolerances. Protect formwork against heavy rain or sunlight.	Inspection: Site foreperson. If necessary, initiate required acceptance of the forming area.
--	---

Additional information on formwork and anchor points:

Coordinate formation of the anchor cones and closing the clamping holes.
 Dense anchor cones due to careful tightening of the anchor nuts and possible use of foam sealing.
 Sealing of the formwork: elements one below the other, to ground contact area, to existing concrete components, Slab/wall connection;
 Sealing of box outs, stopend formwork, reinforcement connections, other mounting parts.
 Sealing with closed-cell, elastic sealing tape. The sealing tape must not leave any impressions on the concrete surface (test it!).
 Use the same formlining for filler areas and elements.
 Arrange trapezoidal borders, chamfer strips, rectangular strips on the construction joints.
 Clamp the formwork onto the previous concreting section.

Adjust formwork if necessary.	Responsible: Site foreperson.
-------------------------------	-------------------------------

Damage to and soiling of the architectural concrete formwork must be avoided during subsequent trade work and other items of work. In particular, the following is prohibited: <ul style="list-style-type: none"> ■ Inscriptions and markings on the concrete side of the formwork (no pencil, no chalk lines); ■ Auxiliary nails or similar for fixing the reinforcement in the formwork; ■ Position reinforcement directly on the formwork (slab formwork) or pull it over the formwork; ■ When installing mounting components in the formwork, ensure no damage is made to the formlining surface; ■ Welding work is to be excluded or if carried out ensure that no flying sparks damage the formlining. 	Subsequent trade work personnel and site workers must be briefed and supervised regarding the special features of the architectural concrete formwork. Responsible: Site foreperson.
--	---

11 Architectural concrete working instructions for the construction site

Work instructions	Measures/controls
<p>Box-outs and mounting parts are attached to the formwork so that the formlining is damaged as little as possible (nail holes, use of double-headed nails, striking with a nail puller).</p>	<p>Inspection: Site foreperson.</p>
<p>Before forming, carefully clean (blow out) the areas of the architectural concrete formwork so no traces of binding wire, reinforcement, nails, wood waste, etc. could then be found on the concrete surface.</p>	<p>Final acceptance of the formwork by the responsible site manager. Focus of inspections:</p> <ul style="list-style-type: none"> ■ Dimensional accuracy (compliance with tolerances). ■ Compliance with formwork plan specifications. ■ Checking connecting means, anchors, push-pull props. ■ Tightness of the formwork.
<p>Reinforcement work: No damage and soiling of the architectural concrete formwork. Quantity and selection of reinforcement spacers. Arrangement of chute entry points and vibrator holes.</p>	<p>Inspection: Site foreperson.</p>
<p>General information - reinforcement: Sufficient spacing of the reinforcement bars so that the concrete is not blocked; install enough spacers between the reinforcement and formwork; for slabs, take the weight of the reinforcement into consideration; Preference is given to concrete spacers over plastic spacers, possibly pre-wetted; Provide support for the upper reinforcement layer by means of supports in accordance with the DBV Code of Practice "Supports" (07/2002) – withdrawn. In the process, positioning on the formwork (plastic base) is preferable to standing on the supporting cage or snake-shaped spacers on the lower reinforcement. Slab reinforcement: in case the reinforcement has been installed in the formwork for a longer period before concreting operations begin, cover the reinforcement with tarpaulins, carefully remove any rainwater, possibly use galvanized reinforcement, always use galvanized binding wire.</p>	
<p>Placing of the concrete: Evenly pour concrete in the middle of the formwork without spattering the formwork. Proper use of the internal vibrators (vibrator head diameter, immersion clearance).</p>	<p>Inspection: Site foreperson.</p>
<p>General information - concrete selection/delivery plant: Concrete must not be prone to bleeding, carry out lab tests, aim for a high proportion of powdered aggregates and fine sand for binding the water, use the permissible limits of DIN 1045 for this. water/cement value < 0.55, deviation of the water/cement value by 0.02 already results in a noticeable change in the colour. Flow diameter 42 ± 2 cm for standard concrete. Grain size 0/16 as a rule, batch mixture 0/8 with the same cement content and the same water/cement value. check possible use of F5 / F6 or SCC concrete (test pour). same type of cement, same delivery plant, same origin of the aggregates, same admix. when using fly ash, ensure that it always come from the same power plant block. Mixing time at least 1 minute, ideally 2 minutes. Remove residual water or residual concrete from transport mixer truck and mixing plant. The period between mixing and concrete placement should be 45 – 60 minutes, i.e. the delivery plant must not be situated too far away from the construction site.</p> <p>Concrete acceptance: Arrival of the transport mixer truck at regular intervals. Careful check of the delivery note. Check flow diameter for each vehicle, if necessary refuse acceptance.</p> <p>Placing of the concrete: Do not use a crane bucket or a pump, do not use an inclined discharge hopper, do not pour concrete against the reinforcement or pour on the formlining. Concreting entry point a < 1.50 m, drop height < 1.50 m, no pouring cone, better to immerse the hose in previous pour. Do not distribute concrete with vibrators. Fill levels max. 0.50 m, better 0.30 m thick.</p>	

Work instructions	Measures/controls
-------------------	-------------------

Use small vibrator diameter, wall thickness 24 cm = vibrator heads – $\varnothing \leq 40$ mm.
 Spacing of vibrating positions (vibrator entry points) approx. 6 – 7 x vibrator diameter.
 "Merge" the new with the old fill level, immerse vibrator approx. 10 – 15 cm preceding layer.
 Do not touch the reinforcement with the vibrator head piece, this prevents the reinforcement grid from being shown on the concrete surface.
 Reduce blowhole accumulation in the upper wall area by re-compacting.
 Use hydraulic external vibrators for inclined slab surfaces and high degree of reinforcement (consult specialist company, e.g. Mooser Tel. +49 98 804348).
 Keep spare vibrator and transformer in reserve.

Create sample components:

Same formwork/formlining, same concrete, same component dimensions (especially wall height), same degree of reinforcement.
 Do not create sample components in the best possible quality. Otherwise problems will occur if the individual building components do not subsequently achieve this quality.

Defining the striking schedule depending on the striking strength. Release the formwork from the concrete in pairs and lift away immediately. Quickly strip the complete wall or slab surface.	Determined by site manager. Inspection: Site foreperson.
---	---

Instructions for post-treatment:

Prevent condensation water, therefore release wall formwork and remove immediately.
 Post-treatment film or tarpaulins must not touch the wall surface.
 Avoid streaks and lime efflorescence due to water running down wall surfaces, no striking operations during rainfall, drain off/remove stagnant water from the wall crown.

Clean formwork panels immediately, check for possible damage and arrange for any necessary repairs.	Responsible: Supervisor.
---	--------------------------

Properly treat the formwork with a release agent ready for next use.	Responsible: Supervisor.
--	--------------------------

Storage of the formwork elements: <ul style="list-style-type: none"> ■ Vertically-positioned sections leaning against existing walls or auxiliary scaffolding, torsion-resistant storage. ■ Use sufficient stacking support and intermediate timbers. ■ Avoid any damage to the edges when setting down, turning and erecting. ■ Protect formlining against soiling, rain and sunlight. ■ Storage areas and working areas for cleaning and release agent treatment of the formwork must be specified. 	Inspection: Site foreperson.
--	------------------------------

Miscellaneous:

- Rust streaks on walls from protruding connecting reinforcement
- Cover connecting reinforcement with foil or coat with cement slurry immediately after concreting.
 Important: structural engineers often require the meticulous removal of cement slurry.
 - Protect walls against escaping concrete laitance when concreting the slab.
 - Constant cleaning of the walls when concreting the slab.
-
- A better option is tightly masking the walls with foil. The adhesive of the adhesive tape must not remain on the concrete after removal.
 - Do not clean the slab formwork with a steam cleaner, excessive and uneven loss of release agent, rod and snake-shaped spacers act as dirt traps during blowing operations.
 - Wear clean shoes when working on the slab formwork, also applies to rebar placement workers and other trades.
 - After applying the release agent, do not use a table saw near open slab formwork.
 - Install edge protection for sharp-edged corners immediately after striking.

Set up QA plan.

PERI International

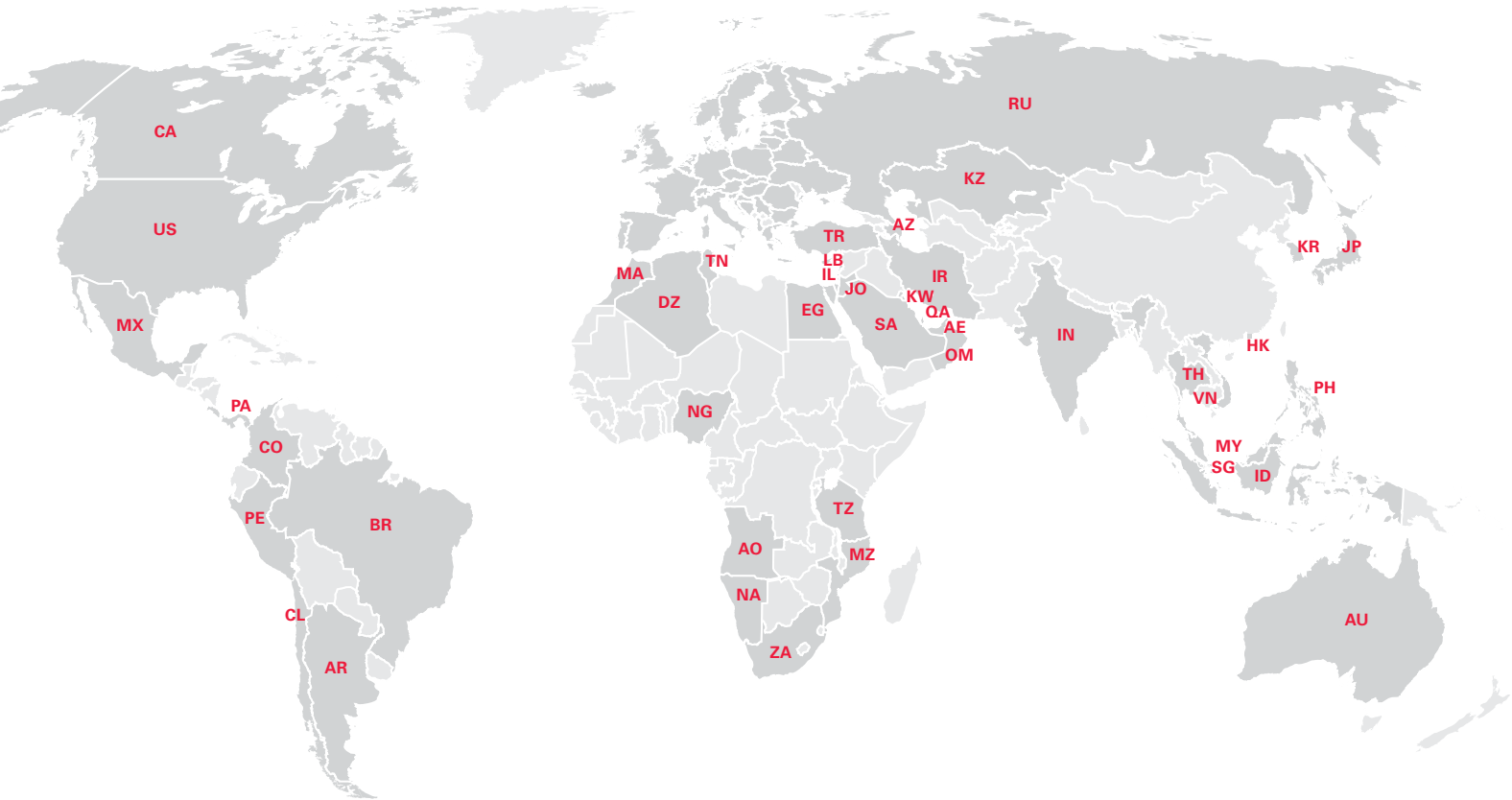

North America

- CA** Canada
PERI Formwork Systems, Inc.
www.peri.ca
- MX** Mexico
PERI Cimbras y Andamios, S.A. de C.V.
www.peri.com.mx
- PA** Panama
PERI Panama Inc.
www.peri.com.pa
- US** USA
PERI Formwork Systems, Inc.
www.peri-usa.com

South America

- AR** Argentina
PERI S.A.
www.peri.com.ar
- BR** Brazil
PERI Formas e Escoramentos Ltda.
www.peribrasil.com.br
- CL** Chile
PERI Chile Ltda.
www.peri.cl
- CO** Colombia
PERI S.A.S.
www.peri.com.co
- PE** Peru
PERI Peruana S.A.C.
www.peri.com.pe

Africa

- AO** Angola
Pericofragens, Lda.
www.peri.pt
- DZ** Algeria
S.A.R.L. PERI
www.peri.dz
- EG** Egypt
Egypt Branch Office
www.peri.com.eg
- MA** Morocco
PERI S.A.
www.peri.ma
- MZ** Mozambique
PERI (Pty.) Ltd.
www.peri.co.mz
- NA** Namibia
PERI (Pty.) Ltd.
www.peri.na
- NG** Nigeria
PERI Nigeria Ltd.
www.peri.ng
- TN** Tunisia
PERI S.A.U.
www.peri.es
- TZ** Tanzania
PERI Formwork and Scaffolding Ltd
www.peri.co.tz
- ZA** South Africa
PERI Formwork Scaffolding (Pty) Ltd
www.peri.co.za

Asia

- AE** United Arab Emirates
PERI (L.L.C.)
www.peri.ae
- AZ** Azerbaijan
PERI Representative Office
www.peri.com.tr
- HK** Hong Kong
PERI (Hong Kong) Limited
www.perihk.com
- ID** Indonesia
PT Beton Perkasa Wijaksana
www.betonperkasa.com
- IL** Israel
PERI F.E. Ltd.
www.peri.co.il
- IN** India
PERI (India) Pvt Ltd
www.peri.in
- IR** Iran
PERI Pars. Ltd.
www.peri.ir
- JO** Jordan
PERI GmbH – Jordan
www.peri.com
- JP** Japan
PERI Japan K.K.
www.peri.co.jp
- KR** Korea
PERI (Korea) Ltd.
www.perikorea.com
- KW** Kuwait
PERI Kuwait W.L.L.
www.peri.com.kw
- KZ** Kazakhstan
TOO PERI Kazakhstan
www.peri.kz
- LB** Lebanon
PERI Lebanon Sarl
lebanon@peri.de
- MY** Malaysia
PERI Formwork Malaysia Sdn. Bhd.
www.perimalaysia.com
- OM** Oman
PERI (L.L.C.)
www.peri.ae
- PH** Philippines
PERI-Asia Philippines, INC.
www.peri.com.ph
- QA** Qatar
PERI Qatar LLC
www.peri.qa
- SA** Saudi Arabia
PERI Saudi Arabia Ltd.
www.peri.com.sa
- SG** Singapore
PERI Asia Pte Ltd
www.periasia.com
- TH** Thailand
Peri (Thailand) Co., Ltd.
www.peri.co.th
- TR** Turkey
PERI Kalıp ve İskeleleri
www.peri.com.tr
- VN** Vietnam
PERI ASIA PTE LTD
www.peri.com.vn



PERI

PERI GmbH Formwork Scaffolding Engineering

Rudolf-Diesel-Strasse 19
89264 Weissenhorn
Germany
Tel. +49 (0)7309.950-0
Fax +49 (0)7309.951-0
info@peri.com
www.peri.com

Oceania

AU Australia
PERI Australia Pty. Ltd.
www.periaus.com.au

DK Denmark
PERI Danmark A/S
www.peri.dk

IT Italy
PERI S.r.l.
www.peri.it

SE Sweden
PERI Sverige AB
www.peri.se

Europe

EE Estonia
PERI AS
www.peri.ee

LT Lithuania
PERI UAB
www.peri.lt

SI Slovenia
PERI oplate i skele d.o.o
www.peri.com.hr

AL Albania
PERI Kalıp ve İskeleleri
www.peri.com.tr

ES Spain
PERI S.A.U.
www.peri.es

LU Luxembourg
N.V. PERI S.A.
www.peri.lu

SK Slovakia
PERI spol. s. r.o.
www.peri.sk

AT Austria
PERI Ges.mbh
www.peri.at

FI Finland
PERI Suomi Ltd. Oy
www.perisuomi.fi

LV Latvia
PERI SIA
www.peri-latvija.lv

UA Ukraine
TOW PERI
www.peri.ua

BA Bosnia and Herzegovina
PERI oplate i skele d.o.o
www.peri.com.hr

FR France
PERI S.A.S.
www.peri.fr

NL Netherlands
PERI b.v.
www.peri.nl

BE Belgium
PERI N.V.
www.peri.be

GB United Kingdom
PERI Ltd.
www.peri.ltd.uk

NO Norway
PERI Norge AS
www.peri.no

BG Bulgaria
PERI Bulgaria EOOD
www.peri.bg

GR Greece
PERI Hellas Ltd.
www.perihellas.gr

PL Poland
PERI Polska Sp. z o.o.
www.peri.com.pl

BY Belorussia
IOOO PERI
www.peri.by

HR Croatia
PERI oplate i skele d.o.o.
www.peri.com.hr

PT Portugal
Pericofragens Lda.
www.peri.pt

CH Switzerland
PERI AG
www.peri.ch

HU Hungary
PERI Kft.
www.peri.hu

RO Romania
PERI România SRL
www.peri.ro

CZ Czech Republic
PERI spol. s r.o.
www.peri.cz

IR Ireland
Siteserv Access & Formwork
www.siteservaccess.ie

RS Serbia
PERI oplate d.o.o.
www.peri.rs

DE Germany
PERI GmbH
www.peri.de

IS Iceland
Armar ehf.
www.armor.is

RU Russia
OOO PERI
www.peri.ru



**Formwork
Scaffolding
Engineering**

www.peri.com

