

# PERI kvalitātes prasības

## MULTIPROP



### Kontakti

**PERI SIA**  
**Betonēšanas veidņi**  
**Tehniskie risinājumi**  
**Sastatnes**  
 Rudeņi 6, Salaspils nov.,  
 LV-2118, Latvija  
 info@peri-latvija.lv

Saturs	Lpp.
MULTIPROP stute	2
Rāmis MRK	11
Piederumi	16
Vārdnīca	36

Izmaiņas	Datums   Autors	Lpp.
Jaunā versija	09/2015   fw	
20.05.03 Mērlente trūkst   saplēsta pievienots	02/2017   fw	4
20.05.05 Ja caurums ≤ 5 mm pievienots	02/2017   fw	4
20.05.09 vecā versija: bez uzlabojumiem pievienots	02/2017   fw	6
20.05.12 Stute arvien kustas pievienots	02/2017   fw	11
20.05.14 Jauns attēls	02/2017   fw	12
20.05.52/ 53/ 54/ 55 Jauns	02/2017   fw	7/8/14
20.05.56 Jauns	05/2018   fw	9
Jauni bojājumi MP stute pievienots	05/2018   fw	33-34

# PERI kvalitātes prasības

## MULTIPROP





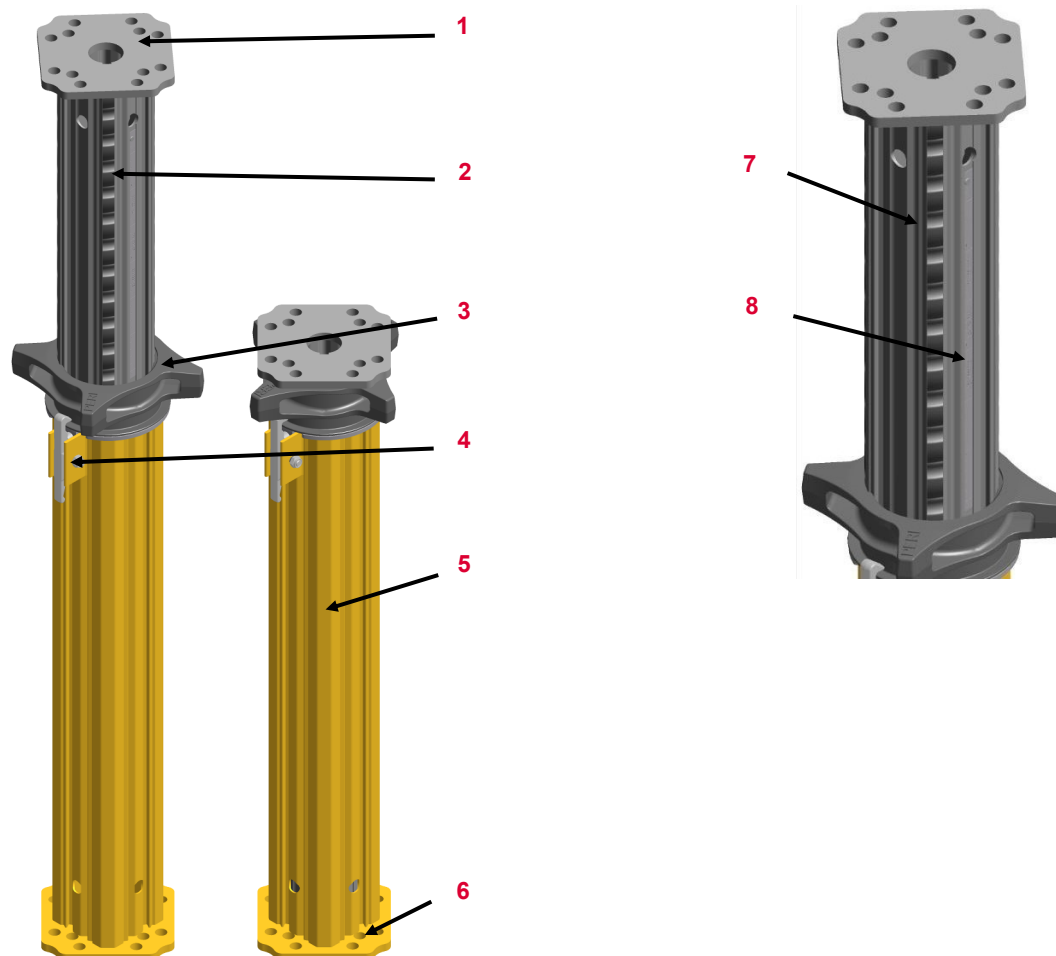



















MULTIPROP stute		Nr.	Nosaukums	Artikula Nr.
-----------------	--	-----	-----------	--------------



1	Augšējā plātne	
2	Iekšējā caurule	
3	Manžete	710273
4	Sprūds	710418
5	Ārējā caurule	
6	Pamata plātne	
7	Vītne	
8	Atloks	















Attiecināms uz	Artikula Nr.
MULTIPROP MP 120	027288
MULTIPROP MP 250	027289
MULTIPROP MP 350	027290
MULTIPROP MP 480	027291
MULTIPROP MP 625	027305

Stute	Apraksts	Darbība	Izmaksas	Tips
	<b>20.05.01 Bukte uz ārējās caurules</b>			
	<ul style="list-style-type: none"> <li>Ja caurule nekustas</li> </ul>		 088381	
	<ul style="list-style-type: none"> <li>Ja ārējā caurule nav remontējama un ja iespējams</li> </ul>	 Ārējās caurules nomaiņa	 Sk. tab. (10 lpp.)	
	<ul style="list-style-type: none"> <li>Vai ja nomaiņa nav iespējama</li> </ul>	 		
	<b>20.05.02 Bukte uz iekšējās caurules</b>			
	<ul style="list-style-type: none"> <li>Caurule nekustas</li> </ul>	 iekšējās caurules nomaiņa	 Sk. tab. (10 lpp.)	
	<ul style="list-style-type: none"> <li>Vai &gt; 2 mm vītnes zonā un ja iespējams</li> <li>Vai &gt; 3 mm atloka zonā</li> </ul>	 iekšējās caurules nomaiņa	 Sk. tab. (10 lpp.)	
	<ul style="list-style-type: none"> <li>Vai ja nav iespējams nomainīt</li> </ul>	 		

Stute	Apraksts	Darbība	Izmaksas	Tips	
	<b>25.05.03 Stipri netīra iekšējā caurule   mērlenta</b>				
	<ul style="list-style-type: none"> <li>■ Ja iespējams notīrīt</li> <li>■ Vai ja nav iespējams notīrīt</li> <li>■ Vai ja mērlente bojāta   trūkst</li> </ul>	 	Nomainīt mērlenti   cauruli	 	Sk. tab. (10 lpp.)
	<b>25.05.04 Vaļīga sliece</b>			088380	
	<b>25.05.05 Caurums ārējā caurulē</b>				
	<ul style="list-style-type: none"> <li>■ <math>\leq \varnothing 5 \text{ mm}</math></li> <li>■ <math>&gt; \varnothing 5 \text{ mm}</math></li> </ul>	  	Nomainīt ārējo cauruli	 	Sk. tab. (10 lpp.)

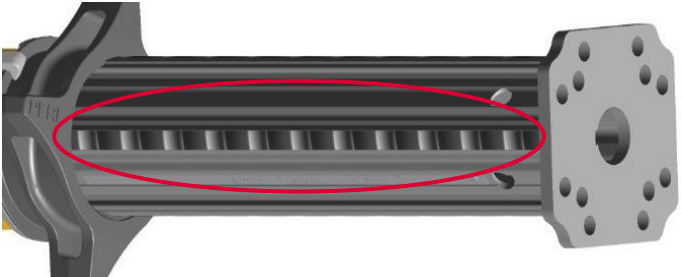









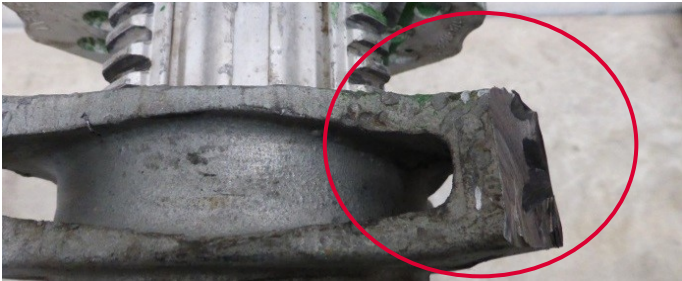



# PERI kvalitātes prasības MULTIPROP

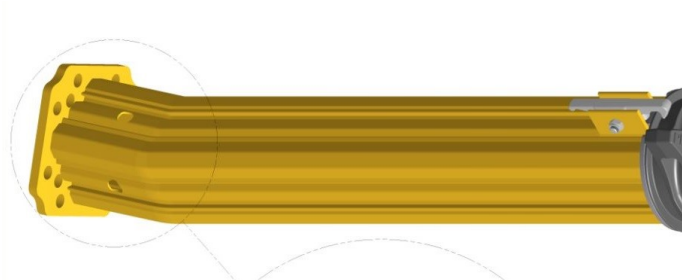

Prop	Apraksts	Darbība	Izmaksas	Tips	
	<b>20.05.06 Salocīta augšējā vai pamata plātne</b> <ul style="list-style-type: none"> <li>■ Izliekums <math>\leq 20</math> mm</li> </ul>				
	<ul style="list-style-type: none"> <li>■ Vai izliekums <math>&gt; 20</math> mm</li> </ul>		Nomainīt iekšējo vai ārējo cauruli		Sk. tab. (10 lpp.) 
	<b>20.05.07 Plaša metinājuma šuvē</b>		Nomainīt iekšējo vai ārējo cauruli		Sk. tab. (10 lpp.) 
	<b>20.05.08 Betona paliekas vītnes zonā</b>				

# PERI kvalitātes prasības MULTIPROP



Stute	Apraksts	Darbība	Izmaksas	Tips
	<b>20.05.09 Manžete (vecā versija: bez uzlabojumiem)</b>	  	 088378	
	<ul style="list-style-type: none"> <li>■ Izrauti gabali</li> </ul>		<ul style="list-style-type: none"> <li>■ Vai plaisa manžetē</li> </ul>	 088378
	<b>20.05.10 Sprūda bojājums   ne-funkcionē</b>		 088372	
	<b>20.05.11 Pilnībā saliekta stute (abas caurules saliekta)</b>	 		
	<ul style="list-style-type: none"> <li>■ Caurule nekustas</li> </ul>			



# PERI kvalitātes prasības MULTIPROP



Stute	Apraksts	Darbība	Izmaksas	Tips
-------	----------	---------	----------	------



20.05.52 Plaisas manžetē (jaunā versija ar uzlabojumiem)



710273







Jaunā versija ar uzlabojumiem (no 2015)

Vecā versija (līdz 2015)



# PERI kvalitātes prasības MULTIPROP



Stute	Apraksts	Darbība	Izmaksas	Tips
	<p>✓</p> <p>20.05.53 Kopija   viltojums</p> <ul style="list-style-type: none"><li>■ Identifikācija uz manžetes (PERI marķējums)</li></ul>			
	<p>✗</p>			



# PERI kvalitātes prasības MULTIPROP



Stute	Apraksts	Darbība	Izmaksas	Tips
	<b>20.53.56 Augšējās plāksnes plaisa   zāģējums</b>	 Iekšējās caurules nomaiņa		

# PERI kvalitātes prasības

## MULTIPROP



Nosaukums	Mērlentes nomaiņa		Ārējās caurules nomaiņa		Iekšējās caurules nomaiņa	
	Rezerves daļa	Servisa artikula Nr.	Rezerves daļa	Servisa artikula Nr.	Rezerves daļa	Servisa artikula Nr.
MULTIPROP MP 120	710421	088370	702048	088401	702050	088400
MULTIPROP MP 250	710406	088374	702038	088403	702040	088402
MULTIPROP MP 350	710414	088375	702029	088405	702028	088404
MULTIPROP MP 480	710407	088376	702034	088407	720606	088406
MULTIPROP MP 625	720609	088373	720603	088409	720606	088408

# PERI kvalitātes prasības

## MULTIPROP



MULTIPROP rāmis MRK		Nr.	Nosaukums	Artikula Nr.
---------------------	--	-----	-----------	--------------

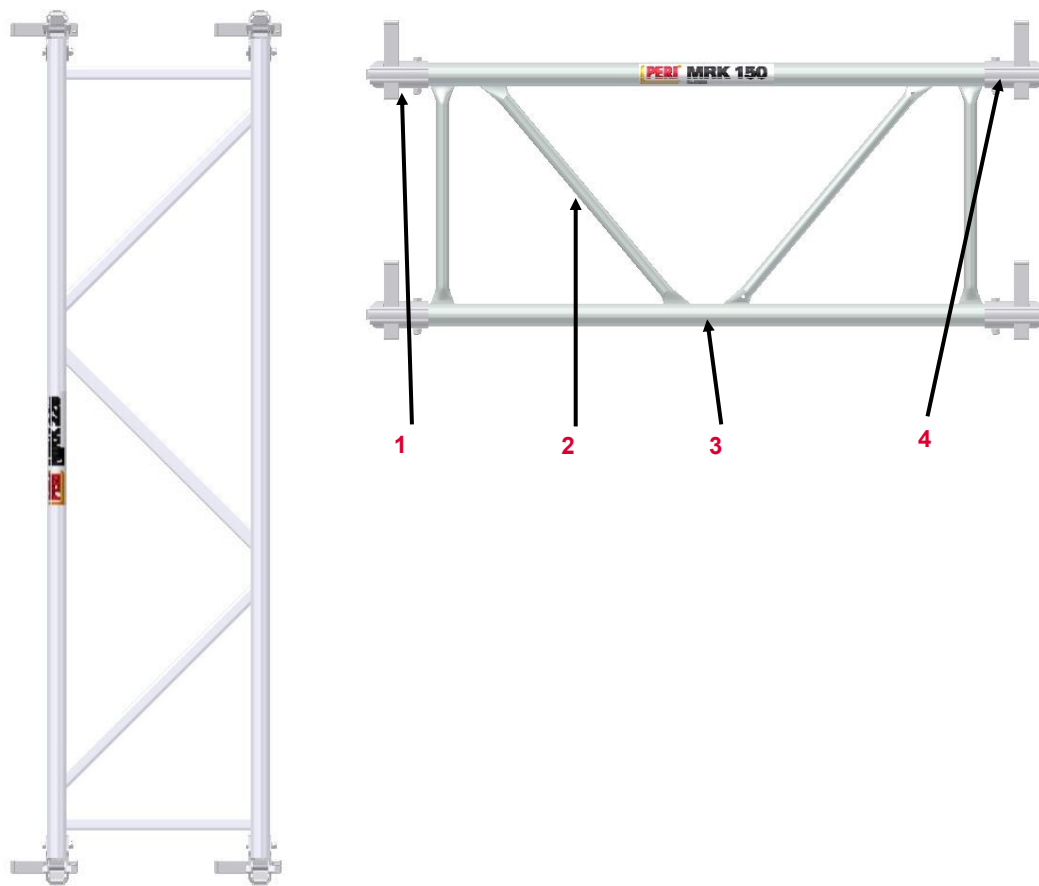









1	Savienotājs C	105881
2	Statnis	
3	Rāmis	
4	Savienotājs D	105874

Valid for	Artikula Nr.
Rāmis MRK 62,5	028390
Rāmis MRK 75	028400
Rāmis MRK 90	028330
Rāmis MRK 120	028340
Rāmis MRK 137,5	028380
Rāmis MRK 150	028350
Rāmis MRK 201,5	028460
Rāmis MRK 225	028360
Rāmis MRK 230	028470
Rāmis MRK 237	028480
Rāmis MRK 266	028490
Rāmis MRK 296	028370

# PERI kvalitātes prasības MULTIPROP



Rāmis MRK	Apraksts	Darbība	Izmaksas	Tips
	<b>20.05.12 Savienotājs nefunkcionē (stute nekustas)</b>	 105881 (Savienotājs C) 105874 (Savienotājs D)		
	<b>20.05.13 Savienotājs saliekts   deformēts</b>	 105881 (Savienotājs C) 105874 (Savienotājs D)	 088379	

Rāmis MRK	Apraksts	Darbība	Izmaksas	Tips
-----------	----------	---------	----------	------

### 20.05.14 Saliekts Rāmis



■ ≤ pieļaujamais izliekums (l/500)















■ Vai > pieļaujamais izliekums



Article	Perm. bent
MRK 62,5	3,0 mm
MRK 75	3,0 mm
MRK 90	3,0 mm
MRK 120	3,0 mm
MRK 137,5	3,0 mm
MRK 150	3,0 mm
MRK 201,5	4,0 mm
MRK 225	4,5 mm
MRK 230	4,5 mm
MRK 237	5,0 mm
MRK 266	5,0 mm
MRK 296	6,0 mm

# PERI kvalitātes prasības MULTIPROP





















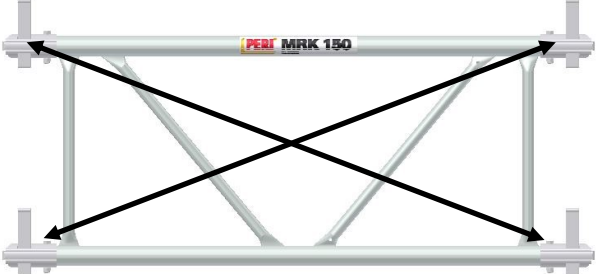

Rāmis MRK	Apraksts	Darbība	Izmaksas	Tips
	<p><b>20.05.15 Kīlis sarūsējis   nolietojies</b></p> <ul style="list-style-type: none"> <li>■ Nefunkcionē</li> </ul>	 <p>105881 (Savienotājs C) 105874 (Savienotājs D)</p>		
	<p><b>20.05.16 Plaisa metinājuma šuvē</b></p> <ul style="list-style-type: none"> <li>■ Bez deformācijas</li> </ul>	 		
	<ul style="list-style-type: none"> <li>■ Vai ar deformāciju</li> </ul>	 		



# PERI kvalitātes prasības MULTIPROP



Rāmis MRK	Apraksts	Darbība	Izmaksas	Tips
	<b>20.05.54 Statnis salocīts</b>			
	<ul style="list-style-type: none"> <li>■ Ja iespējams</li> </ul>			
	<ul style="list-style-type: none"> <li>■ Vai deformētas statņa kantis</li> </ul>	 		
	<ul style="list-style-type: none"> <li>■ Vai bukte statnī</li> </ul>	 		
	<b>20.05.55 MRK saliekts diagonāli</b>			
	<ul style="list-style-type: none"> <li>■ Ja iespējams</li> </ul>			
	<ul style="list-style-type: none"> <li>■ Vai ja nav iespējams</li> </ul>	 		

Pēda MP 50 (027310)	Apraksts	Darbība	Izmaksas	Tips
---------------------	----------	---------	----------	------



### 20.05.17 Caurule saliekta

- ≤ 6 mm dziļumā ≤ Ø 60 mm
- Vai > 6 mm dziļumā
- Vai > Ø 60 mm

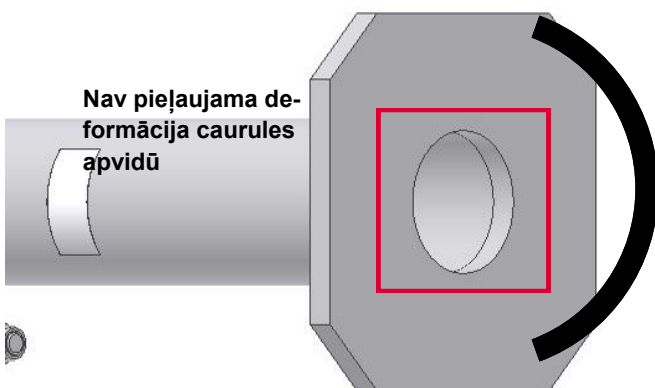















### 20.05.18 Augšējā vai pamata plāksne saliekta

- ≤ 15 mm
- Vai > 15 mm













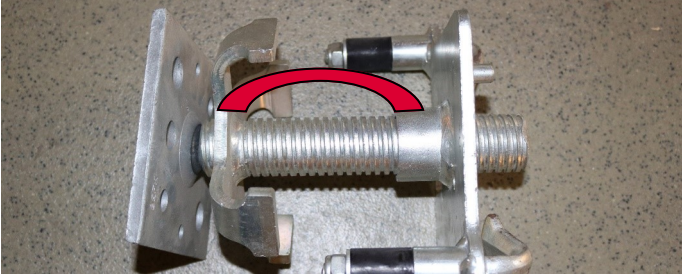

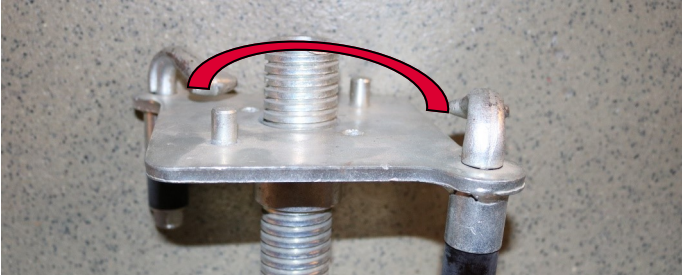

088244



Pēda MP 50 (027310)	Apraksts	Darbība	Izmaksas	Tips
	<p><b>20.05.19 Atspercaurule bojāta, trūkst</b></p> <ul style="list-style-type: none"> <li>■ Atspercauruls 1. versija (melna)</li> <li>■ Vai atspercaurule 2. versija (oranža)</li> </ul>	  	   088367	  
	<p><b>20.05.20 Spriegotājs bojāts   iztrūkst</b></p>	 <p>780108 (Atspercaurule) 780105 (Spriegotājs) 710381 (Uzgrieznis) 780702 (Paplāksne 2x)</p>	 088368	
	<p><b>20.05.21 Spriegotājs nav pievilkts</b></p> <ul style="list-style-type: none"> <li>■ Spriegotājam jābūt pretestībai, kustinot ar roku</li> </ul>			

# PERI kvalitātes prasības MULTIPROP

















Pacelšanas pamatne MKF (027296)	Apraksts	Darbība	Izmaksas	Tips
	<b>20.05.22 Vārpsta saliekta</b>  <ul style="list-style-type: none"> <li>■ &gt; 5 mm</li> </ul>			
	<b>20.05.23 Saliekta augšējā vai pamata plāksne</b>  <ul style="list-style-type: none"> <li>■ &gt; 5 mm</li> </ul>		 088244	
	<b>20.05.23 Saliekts rotors</b>  <ul style="list-style-type: none"> <li>■ Nav plaisas rotorā</li> <li>■ Vai ir plaisa rotorā</li> </ul>	 Ja iespējams  	 088244  	  



# PERI kvalitātes prasības MULTIPROP











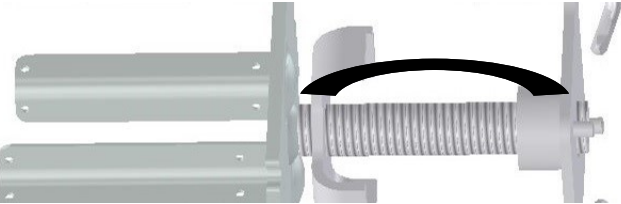













Pamatne MKF (027296)	Apraksts	Darbība	Izmaksas	Tips
	<p><b>20.05.25 Atspercaurule bojāta   iztrūkst</b></p> <ul style="list-style-type: none"> <li>■ Atspercaurule 1. versija (melna)</li> <li>■ Vai atspercaurule 2. versija (oranža)</li> </ul>	  	 088367  	  
	<p><b>20.05.26 Spriegotājs bojāts   trūkst</b></p>	 <ul style="list-style-type: none"> <li>780108 (Atspercaurule)</li> <li>780105 (Spriegotājs)</li> <li>710381 (Uzgrieznis)</li> <li>780702 (Paplāksne 2x)</li> </ul>	 088268	
	<p><b>20.05.27 Spriegotājs nepievilkts</b></p> <ul style="list-style-type: none"> <li>■ Spriegotājam jābūt pretestībai, kustinot ar roku</li> </ul>			

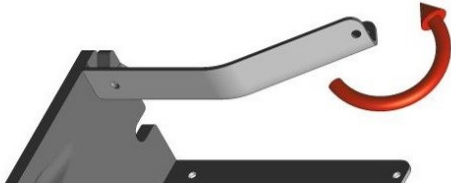













# PERI kvalitātes prasības

## MULTIPROP



Galva MKK (027297)	Apraksts	Darbība	Izmaksas	Tips
	<b>20.05.28 Vārpsta saliekta</b> <ul style="list-style-type: none"> <li>■ &gt; 5 mm</li> </ul>	 		
	<b>20.05.29 Saliekta augšējā vai pamata plāksne</b> <ul style="list-style-type: none"> <li>■ &gt; 5 mm</li> </ul>	 		
	<b>20.05.30 Rotors saliekts</b> <ul style="list-style-type: none"> <li>■ Nav plaisas rotorā</li> <li>■ Vai ir plaisa rotorā</li> </ul>	<ul style="list-style-type: none"> <li>  Ja iespējams                 </li> <li>   </li> </ul>	<ul style="list-style-type: none"> <li>  088244                 </li> <li>  088244                 </li> </ul>	<ul style="list-style-type: none"> <li>  </li> <li>  </li> </ul>
	<b>20.05.31 Rags saliekts</b> <ul style="list-style-type: none"> <li>■ Nav plaisas metinājuma šuvē</li> <li>■ Vai ir plaisa metinājuma šuvē</li> </ul>	<ul style="list-style-type: none"> <li>  </li> <li>  </li> </ul>	<ul style="list-style-type: none"> <li>  088395                 </li> <li>  088394                 </li> </ul>	<ul style="list-style-type: none"> <li>  </li> <li>  </li> </ul>



Galva MKK (027297)	Apraksts	Darbība	Izmaksas	Tips
	<p><b>20.05.32 Atspercaurule bojāta   iztrūksts</b></p> <ul style="list-style-type: none"> <li>■ Atspercaurule 1. versija (melna)</li> <li>■ Vai atspercaurule 2. versija (oranža)</li> </ul>	 	  088367	 
	<p><b>20.05.33 Spriegotājs bojāts   iztrūksts</b></p>	 <p>780108 (Atspercaurule)            780105 (Spriegotājs)            710381 (Uzgrieznis)            780702 (Paplāksne 2x)</p>	 088368	
	<p><b>20.05.34 Spriegotājs nav pievilkts</b></p> <ul style="list-style-type: none"> <li>■ Spriegotājam jābūt pretestībai, kustinot ar roku</li> </ul>			

# PERI kvalitātes prasības

## MULTIPROP

















Trijkājis (028000)	Nr.	Nosaukums	Artikula Nr.
--------------------	-----	-----------	--------------



1	Pagrieziena kāja	715643
2	Spriegošanas cilpa	710161
3	Uzgrieznis	030130
4	Atbalsta kāja	715642









# PERI kvalitātes prasības MULTIPROP



Trijkājis	Apraksts	Darbība	Izmaksas	Tips
	<b>20.05.35 Pagrieziena kāja</b> <ul style="list-style-type: none"> <li>■ Ja funkcionē</li> <li>■ Vai ja nefunkcionē</li> </ul>	<ul style="list-style-type: none"> <li></li> <li></li> </ul>	<ul style="list-style-type: none"> <li> 088244</li> <li> 089149</li> </ul>	<ul style="list-style-type: none"> <li></li> <li></li> </ul>
	<b>20.05.36 Atbalsta kāja saliekta</b> <ul style="list-style-type: none"> <li>■ Ja iespējams</li> <li>■ Vai ja nav iespējams</li> </ul>	<ul style="list-style-type: none"> <li></li> <li></li> </ul>	<ul style="list-style-type: none"> <li> 088244</li> <li></li> </ul>	<ul style="list-style-type: none"> <li></li> <li></li> </ul>

# PERI kvalitātes prasības MULTIPROP



Trijkājis	Apraksts	Darbība	Izmaksas	Tips
	<b>20.05.37 Savilcējskava deformēta</b>  ■ > 100°			
	<b>20.05.38 Uzgrieznis sabojāts</b>	 030130 (Uzgrieznis) 767043 (Sprosta tapa)	 088429	

# PERI kvalitātes prasības

## MULTIPROP



### Sastatņu caurule

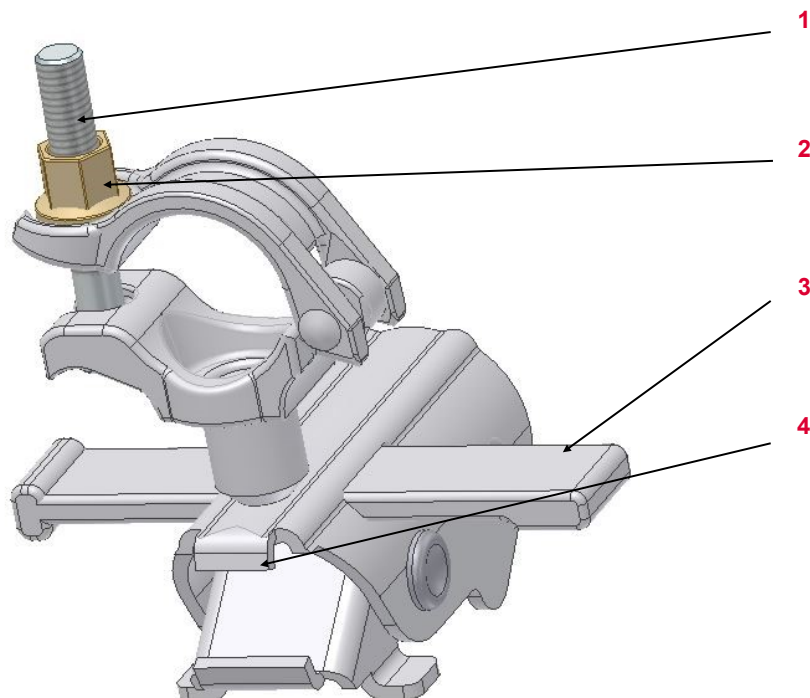

Nr.	Nosaukums	Artikula Nr.
1	Skrūve	710702
2	Uzgrieznis	710340
3	Ķīlis	
4	Savienotājs	











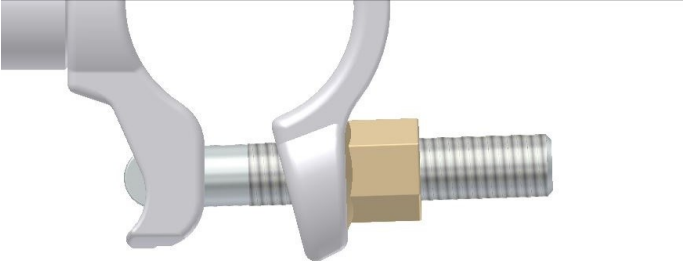

  

Attiecināms uz	Artikula Nr.
Sastatņu caurule MG-A/C	027298
Sastatņu caurule MG-B/D	027299

# PERI kvalitātes prasības

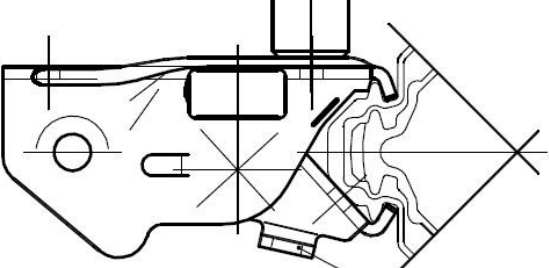
## MULTIPROP



Sastatņu caurule	Apraksts	Darbība	Izmaksas	Tips
	<b>20.05.39</b> Skrūve bojāta   iztrūkst	 710702 (Skrūve) 710340 (Uzgrieznis)	 088388 088360	
	<b>20.05.40</b> Ķīlis nefunkcionē	 		
	<b>20.05.41</b> Nav iespējams savienot ar MULTIPROP stuti	 		



# PERI kvalitātes prasības

## MULTIPROP



Savienotājs MPV-2 (027301)	Apraksts	Darbība	Izmaksas	Tips
----------------------------	----------	---------	----------	------



20.05.42 Skrūve vai atslēga iztrūkst



20.05.43 Deformēts | saliekts



# PERI kvalitātes prasības MULTIPROP



MULTIPROP skava (027302)	Apraksts	Darbība	Izmaksas	Tips
--------------------------	----------	---------	----------	------



20.05.44 Satvērējs saliekts | iztrūkst



20.05.45 Skava saliekta

■ > 10 mm



Spriegotājs (111000)	Apraksts	Darbība	Izmaksas	Tips
----------------------	----------	---------	----------	------

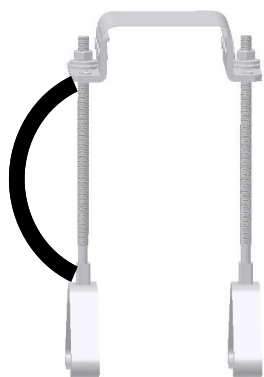

20.05.46 Vītne saliekta

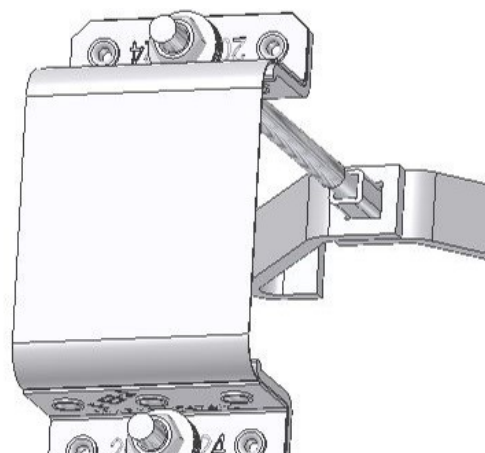

20.05.47 Plāksne bojāta | deformēta



# PERI kvalitātes prasības

## MULTIPROP



### Alumīnija sija MPB 24

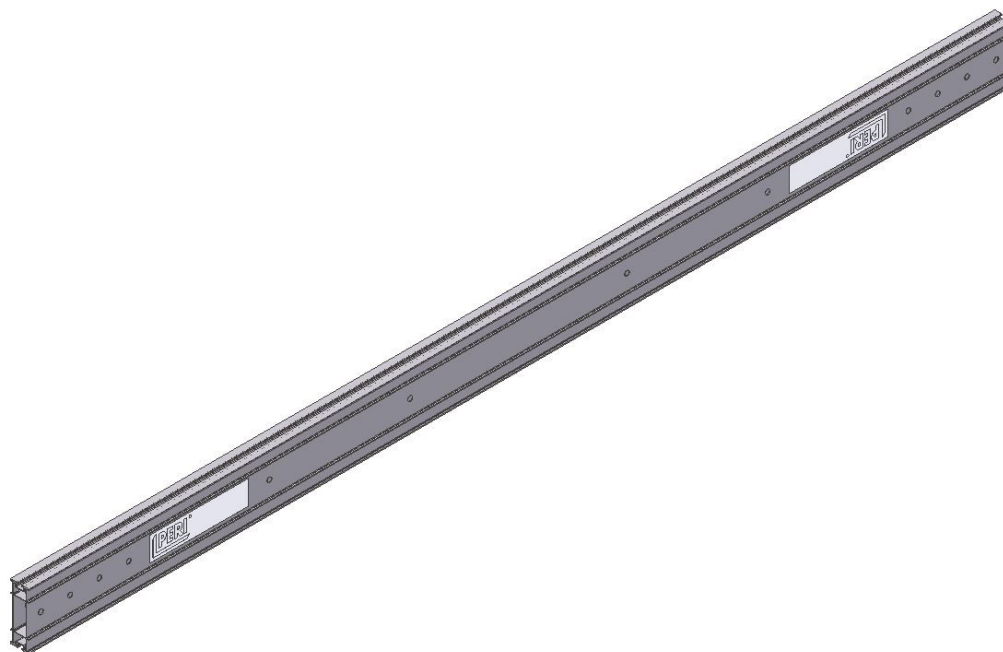











Nr.	Nosaukums	Artikula Nr.
-----	-----------	--------------

Valid for	Artikula Nr.
Sija MPB 24, L= 3,00 m	079300
Sija MPB 24, L= 3,60 m	079360
Sija MPB 24, L= 4,20 m	079420
Sija MPB 24, L= 4,80 m	079480
Sija MPB 24, L= 5,40 m	079540
Sija MPB 24, L= 6,00 m	079600

# PERI kvalitātes prasības MULTIPROP



MPB Sija	Apraksts	Darbība	Izmaksas	Tips
	<b>20.05.48 Naglu caurumi</b>	<ul style="list-style-type: none"> <li>■ ≤ Ø 5 mm</li> </ul>		
	<ul style="list-style-type: none"> <li>■ Vai &gt; Ø 5 mm</li> </ul>	 		
	<b>20.05.49 Sija saīsināta</b>	<ul style="list-style-type: none"> <li>■ Pieļaujams tikai kombinācijā ar atbilstošā vietā uztaisītiem urbumiem</li> </ul>		

# PERI kvalitātes prasības MULTIPROP



MPB Sija	Apraksts	Darbība	Izmaksas	Tips
----------	----------	---------	----------	------

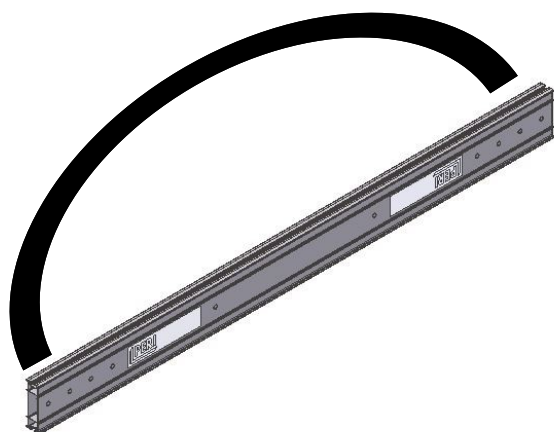

### 20.05.50 Sija saliekta

■ ≤ Pieļaujamā izliece



■ Vai > pieļaujamā izliece













Artikuls	Pieļ. Izl.
MPB 24, L= 3,00 m	6,0 mm
MPB 24, L= 3,60 m	7,0 mm
MPB 24, L= 4,20 m	9,0 mm
MPB 24, L= 4,80 m	9,5 mm
MPB 24, L= 5,40 m	11,0 mm
MPB 24, L= 6,00 m	12,0 mm



# PERI kvalitātes prasības MULTIPROP



MPB Sija	Apraksts	Darbība	Izmaksas	Tips
	<b>20.05.57 Neiztīrīta vadīkla</b>			
	<ul style="list-style-type: none"> <li>■ Ja iespējams</li> </ul>			
	<b>20.05.58 plaisa, robs iekšējā profilā</b>			

# PERI kvalitātes prasības

## MULTIPROP



MPB Sija	Apraksts	Darbība	Izmaksas	Tips
	25.05.59 Plaisa, robs ārējā profilā			

# PERI kvalitātes prasības

## MULTIPROP





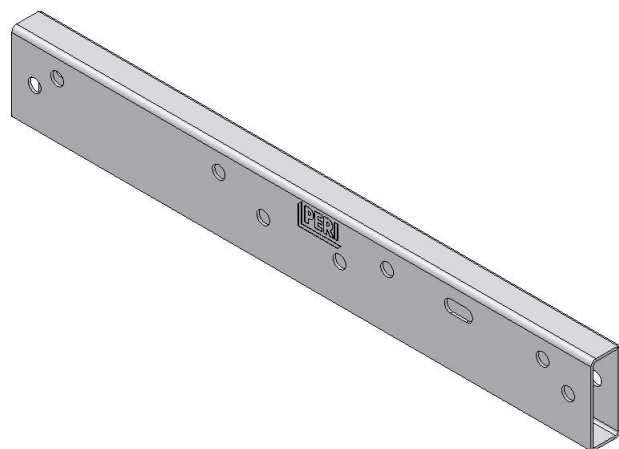













Salaidums MPB (107348)	Apraksts	Darbība	Izmaksas	Tips
------------------------	----------	---------	----------	------



20.05.51 Salaidums saliekts



Ikona	Nozīme	Ikona	Nozīme	Ikona	Nozīme
	Nav derīgs - materiāls jānoraksta		Jāizraksta rēķins (klientam)		Vizuāls bojājums
	Derīgs - materiāls paliek nomas parkā		Rēķins nav jāizraksta		Funkcionāls bojājums
	Norakstāms materiāls – izdošana nomā nav pieļaujama dēļ neatbilstības drošības prasībām		Saīsināt materiālu		Funkcionāls bojājums - izdošana nomā nav pieļaujama
	Remonts saskaņā ar instrukciju		Marķēt materiālu		Statisks bojājums - izdošana nomā nav pieļaujama
	Aukstā labošana – veicot metinājuma šuvju un blakus detaļu pēcpārbaudi		Nomainīt bojāto materiālu		
	Remonts tikai pēc izmaksu tāmes izvērtēšanas		Atvietot trūkstošo materiālu		
	Materiāla tīrīšana				