

PERI kvalitātes prasības

Paletes un kraušanas ierīces

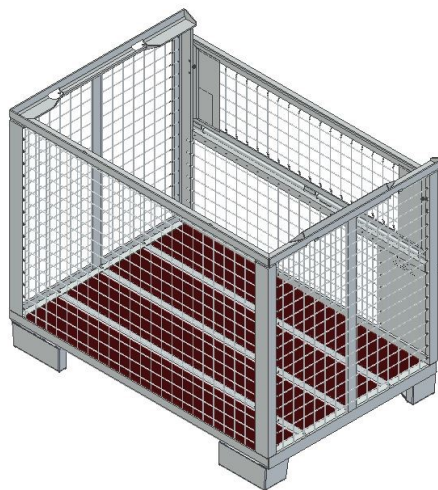

Kontakti

PERI SIA
Betonēšanas veidņi
Tehniskie risinājumi
Sastatnes
Rudeņi 6, Salaspils nov., LV-
2118, Latvija
info@peri-latvija.lv

Saturs	Lpp	Izmaiņas	Datums Autors	Lpp
Režģotā palete Mazā režģotā palete	2	Atjaunotā versija	10/2016 l fw	
Paletes RP- 2	8			
Paletes SD 150 x 225	14			
Paletes ST 100-2	17			
Paletes RP 110 x 125	21			
Paletes SD	23			
Paletes EP 110	25			
Vārdnīca	31			

PERI kvalitātes prasības

Paletes un kraušanas ierīces



Režgotā palete 80 x 120 | Mazā režgotā palete 80 x 120

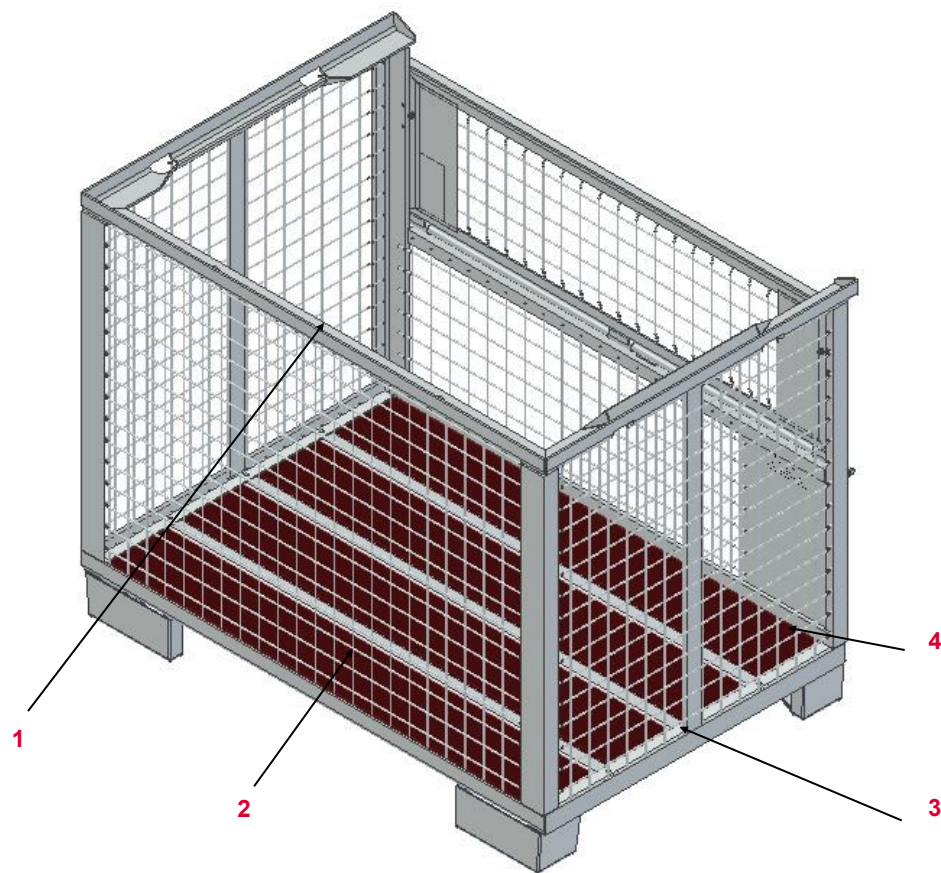

Nr.	Nosaukums	Artikula Nr.
1	Rāmis	
2	Grīda 21 x 156 x 1192	721417
3	Grīdas turētājs	720689
4	Kniede DIN 7337-A4, 8X12-ST	721412

Valid for	Article number
Režgotā palete 80 x 120, galv.	065068
Režgotā palete 80 x120-K, painted	065016
Mazā režgotā palete 80 x 120, galv.	025660
Mazā režgotā palete 80 x 120, painted	025670

PERI kvalitātes prasības

Paletes un kraušanas ierīces



Režgotā palete Mazā režgotā palete	Apraksts	Darbība	Izmaksas	Tips
--------------------------------------	----------	---------	----------	------



32.01 Bukte rāmī



PERI kvalitātes prasības

Paletes un kraušanas ierīces



Režgotā palete Mazā režgotā palete	Apraksts	Darbība	Izmaksas	Tips
--------------------------------------	----------	---------	----------	------



32.02 Uzplēsts siets

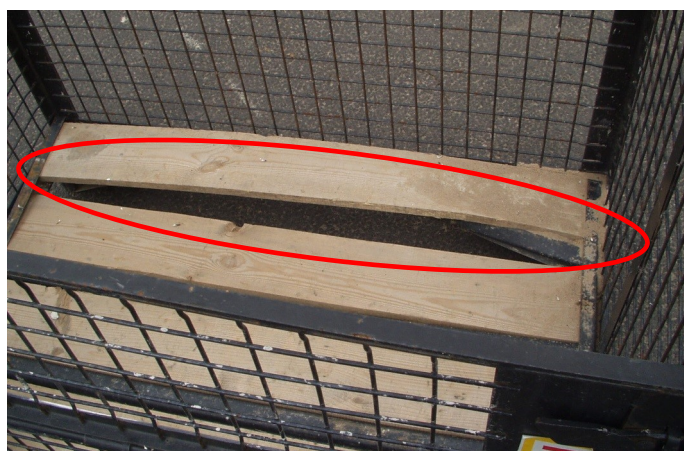

32.03 Grīda

■ Dabiskais nolietojums











■ Vai mehānisks bojājums



PERI kvalitātes prasības

Paletes un kraušanas ierīces



Režgotā palete Mazā režgotā palete	Apraksts	Darbība	Izmaksas	Tips
	32.04 Deformēts vāks ■ Nefunkcionē	 		
	32.05 Deformēta pēda ■ Palete nestāv taisni	 		
	■ Vai droša kraušana un nos- tiprināšana uz citas nav iespējama	 		

PERI kvalitātes prasības

Paletes un kraušanas ierīces



Režgotā palete Mazā režgotā palete	Apraksts	Darbība	Izmaksas	Tips
--------------------------------------	----------	---------	----------	------



32.06 Deformēta pacelšanas atvere



32.07 Paletes marķējums nesalasāms















721400



PERI kvalitātes prasības

Paletes un kraušanas ierīces



Režgotā palete Mazā režgotā palete	Apraksts	Darbība	Izmaksas	Tips
	32.08 Sarūsējusi			
	<ul style="list-style-type: none"> ■ Materiāla zudums < 10% 			
	<ul style="list-style-type: none"> ■ Vai materiāla zudums > 10% 	 		
<ul style="list-style-type: none"> ■ Vai nefunkcionē 	 			

PERI kvalitātes prasības

Paletes un kraušanas ierīces



Paleta RP-2 80 x 120 | 80 x 150 (103434 | 103429)

Nr. Nosaukums Artikula Nr.

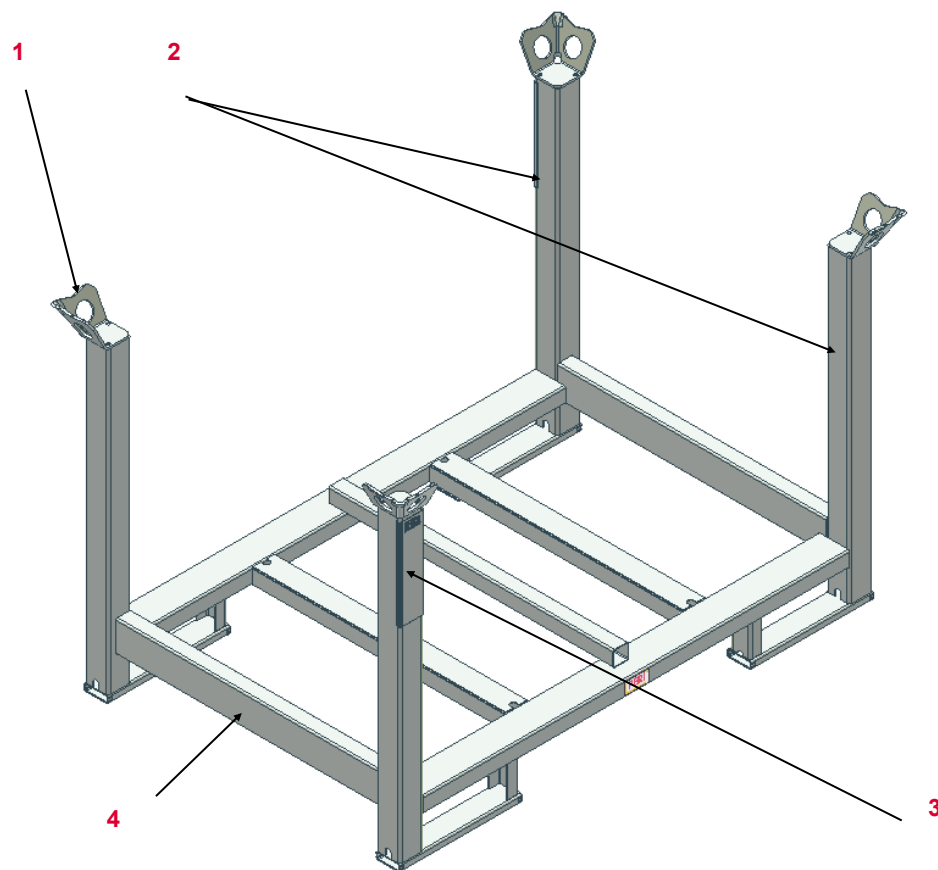

- | | |
|---|---------------------|
| 1 | Pacelšanas atvere |
| 2 | Stute kreisā labā |
| 3 | Marķējums |
| 4 | Horizontālā caurule |

PERI kvalitātes prasības

Paletes un kraušanas ierīces



Paleta SD 150 x 75 (061500)

Nr. Nosaukums Artikula Nr.

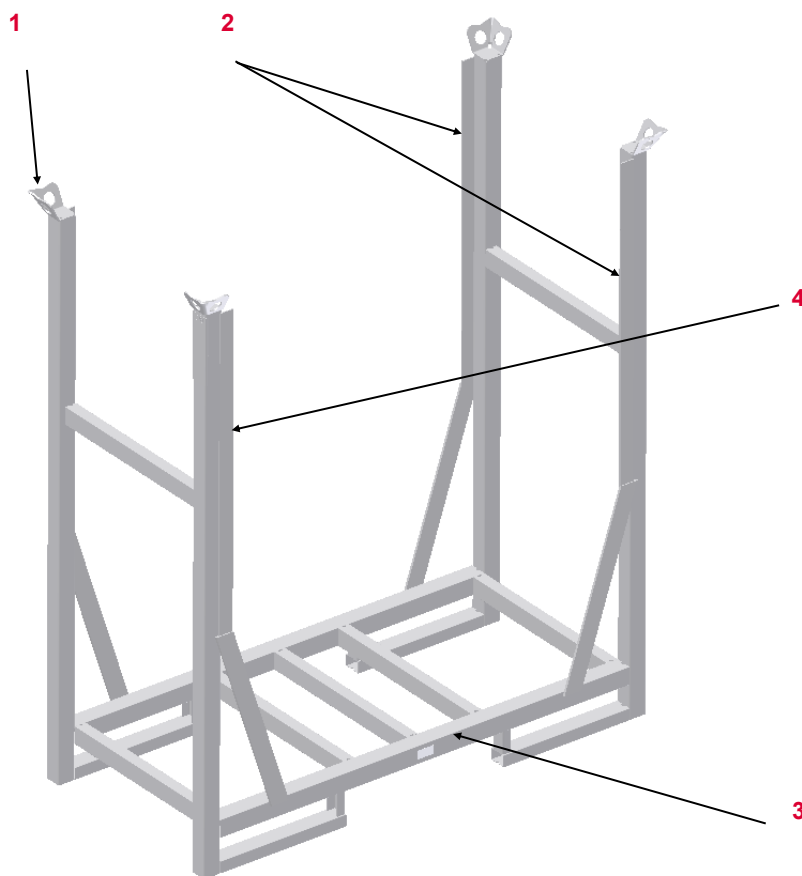

1 Pacelšanas atvere

2 Stute kreisā | labā

3 Horizontālā caurule

4 Aizsargs

PERI kvalitātes prasības

Paletes un kraušanas ierīces



RP-2 80 x 120/150 SD 150 x 75	Apraksts	Darbība	Izmaksas	Tips
---------------------------------	----------	---------	----------	------



32.09 Pacelšanas atveres ieliekums | bukte



32.10 Stutes ieliekums | bukte



PERI kvalitātes prasības

Paletes un kraušanas ierīces



RP-2 80 x 120/150 SD 150 x 75	Apraksts	Darbība	Izmaksas	Tips
---------------------------------	----------	---------	----------	------



32.11 Pacelšanas atveres (foto versija līdz 04/2011) nodilums

- Vispārīgi: vecajā versijā ovāla pacelšanas atvere | jaunajā versijā apaļa pacelšanas atvere
- Versijai līdz 04/2011:
sieniņas atlikums ≤ 16 mm
- Vai versijai no 04/2011:
sieniņas atlikums $\leq 15,7$ mm

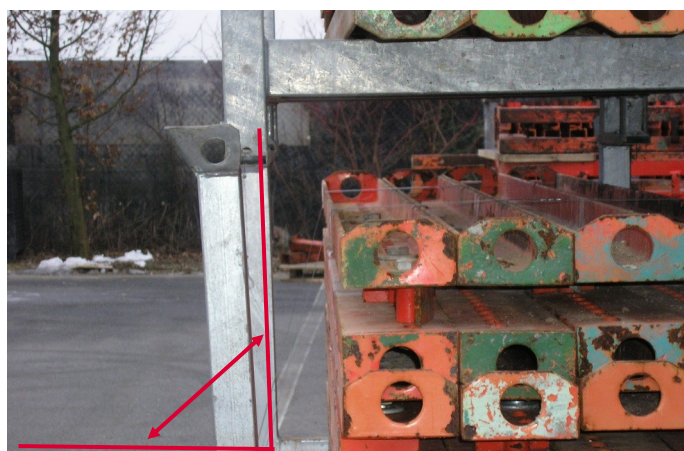

32.12 Stutes izliekums

- Stutes izliekums $> 1^\circ$



PERI kvalitātes prasības

Paletes un kraušanas ierīces



RP-2 80 x 120/150 SD 150 x 75	Apraksts	Darbība	Izmaksas	Tips
---------------------------------	----------	---------	----------	------



32.13 Bukte pēdā



32.14 Horizontālās caurules izliekums



PERI kvalitātes prasības

Paletes un kraušanas ierīces



RP-2 80 x 120/150 SD 150 x 75	Apraksts	Darbība	Izmaksas	Tips
	<p>32.15 Plaisa metinājuma šuvē</p> <ul style="list-style-type: none"> ■ Bez bojājumiem blakus esošās detaļās ■ Vai ar bojājumiem blakus esošās detaļās 	<ul style="list-style-type: none">   	<ul style="list-style-type: none">   	<ul style="list-style-type: none">  

PERI kvalitātes prasības

Paletes un kraušanas ierīces



Paleta SD 150 x 225 (061530)

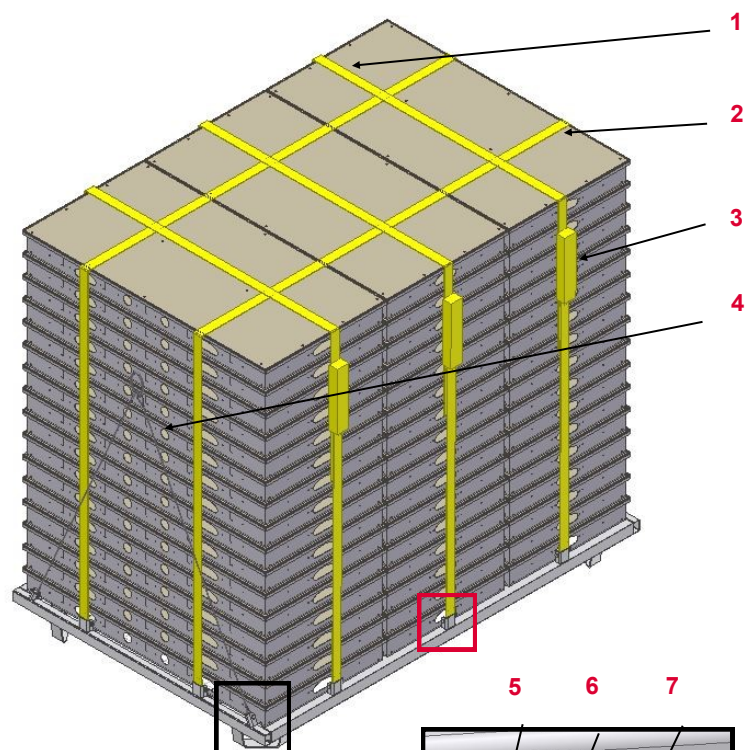

Nr.	Nosaukums	Artikula Nr.
1	Strope L= 4200 ar vaļēju galu	710595
2	Strope L= 5000 ar vaļēju galu	710596
3	Strope ar sprūdratu	710594
4	Cilpa	710597
5	Skrūve M 10 x 50	710335
6	Caurule L= 20	700372
7	Uzgrieznis M 10	780356
8	Skrūve M 10 x 80	710593
9	Skrūve M 10	780356
10	Caurule L = 53	700371

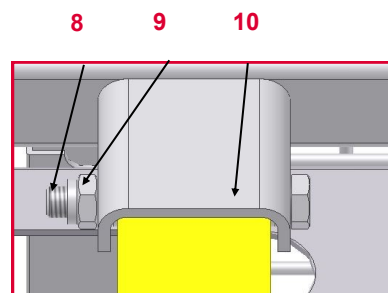
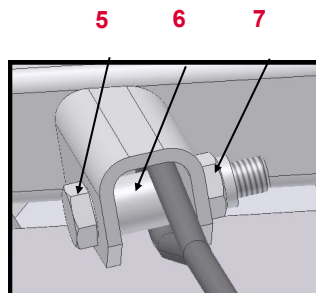

PERI kvalitātes prasības

Paletes un kraušanas ierīces



SD 150 x 225	Apraksts	Darbība	Izmaksas	Tips
--------------	----------	---------	----------	------



32.16 Strope | Rope

- Iztrūkums



710594 (Strope ar sprūdratu)
 710595 (Strope L= 4200)
 710596 (Strope L= 5000)
 710597 (Cilpa)



- Vai mehānisks bojājums



710594 (Strope ar sprūdratu)
 710595 (Strope L= 4200)
 710596 (Strope L= 5000)
 710597 (Cilpa)



PERI kvalitātes prasības

Paletes un kraušanas ierīces



SD 150 x 225	Apraksts	Darbība	Izmaksas	Tips
--------------	----------	---------	----------	------

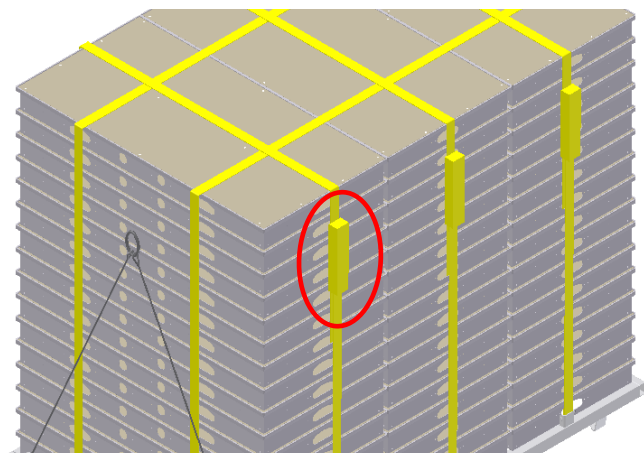

32.17 Pacelšanas strope

- Sprūdrats nefunkcionē



710594 (Strope ar sprūdratu)

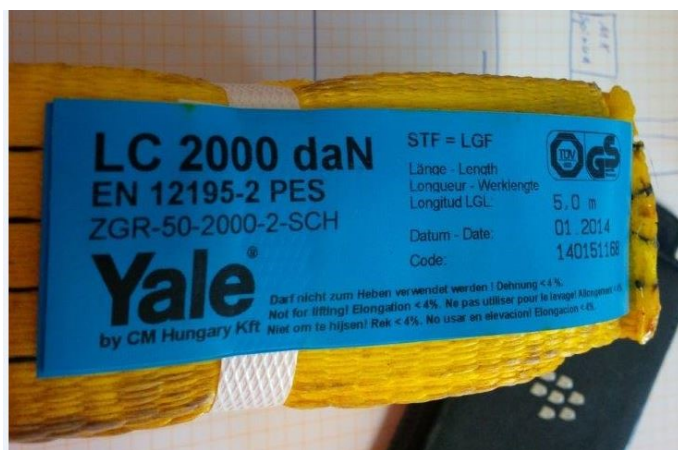

32.18 Pazudis vai nesalasāms stropes marķējums



710594
710595
710596



PERI kvalitātes prasības

Paletes un kraušanas ierīces



Palete ST 100-2 (065050)

Nr.	Nosaukums	Artikula Nr.
-----	-----------	--------------

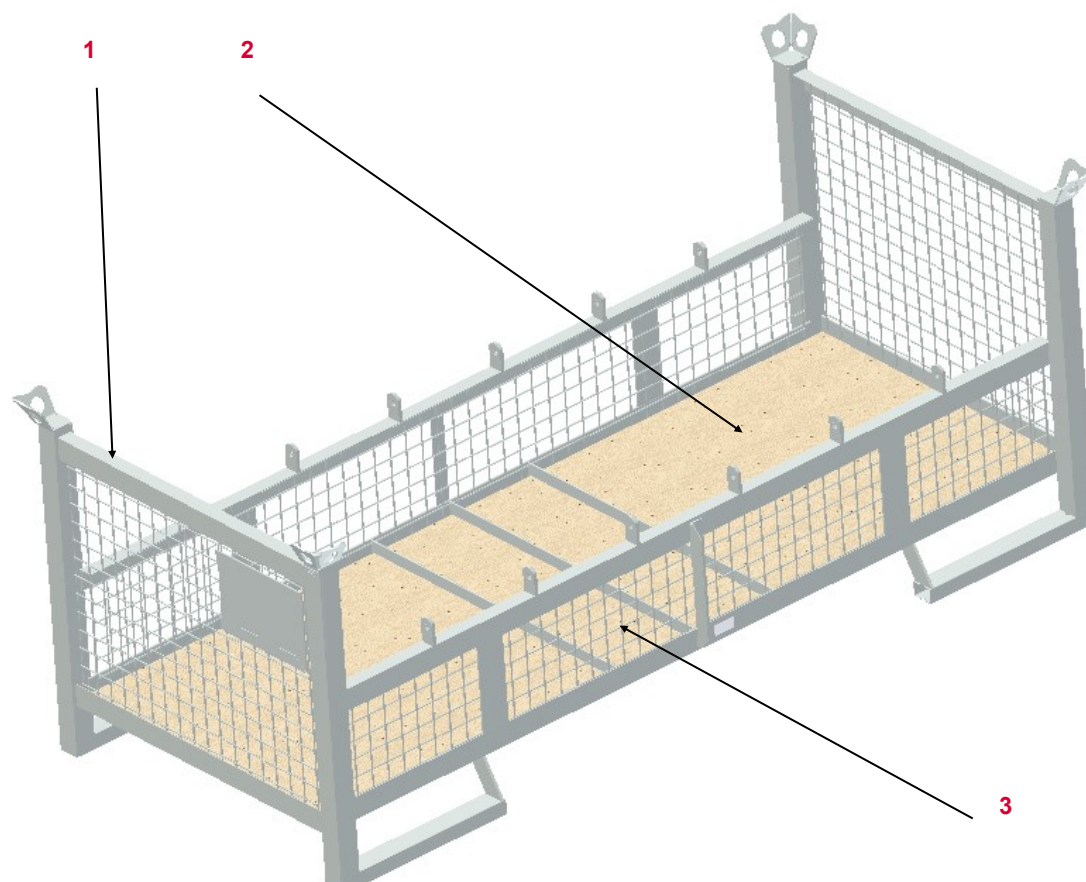









1	Palete ST 100-2 verz.	106514
2	3-S-Plāksne 22mm 870x920	102353
3	3-S-Plāksne 22mm 870x240	102354

PERI kvalitātes prasības

Paletes un kraušanas ierīces









Paletes ST 100-2	Apraksts	Darbība	Izmaksas	Tips
	32.19 Stutes bukte			
	32.20 Pēdas bukte			

PERI kvalitātes prasības

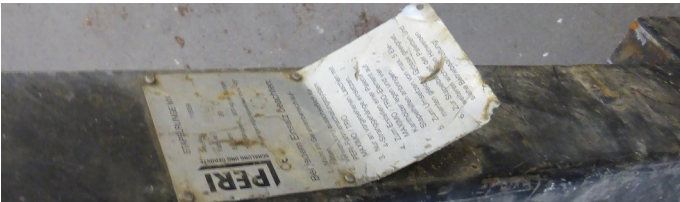
Paletes un kraušanas ierīces















Fiksēšanas ierīce MX (115058)	Apraksts	Darbība	Izmaksas	Tips
	32.21 Salocīts profils			
	32.22 Plaisa metinājuma šuvē	 		
	32.23 Marķējums nesalasāms pazudis			
	32.24 Locījums			

PERI kvalitātes prasības

Paletes un kraušanas ierīces



DOMINO kraušanas ierīce (066094)	Apraksts	Darbība	Izmaksas	Tips
	<p>32.25 Plaisa metinājuma šuvē</p> <ul style="list-style-type: none"> ■ Mehānisks bojājums (Kraušanas ierīce salocīta) ■ Vai cits bojājums (ne mehāniska spēka iedarbības ietekmē) 	<p>   </p> <p>   </p>	<p>  </p> <p>  </p>	<p>  </p> <p>  </p>
	<p>32.26 Marķējuma plāksne nesalasāma pazudusi</p>	<p>  </p> <p>750059 (Marķējuma plāksne) 710217 (Kniede)</p>	<p>  </p>	<p>  </p>

PERI kvalitātes prasības

Paletes un kraušanas ierīces



Paletes RP 110x125	Nr.	Nosaukums	Artikula Nr.
--------------------	-----	-----------	--------------

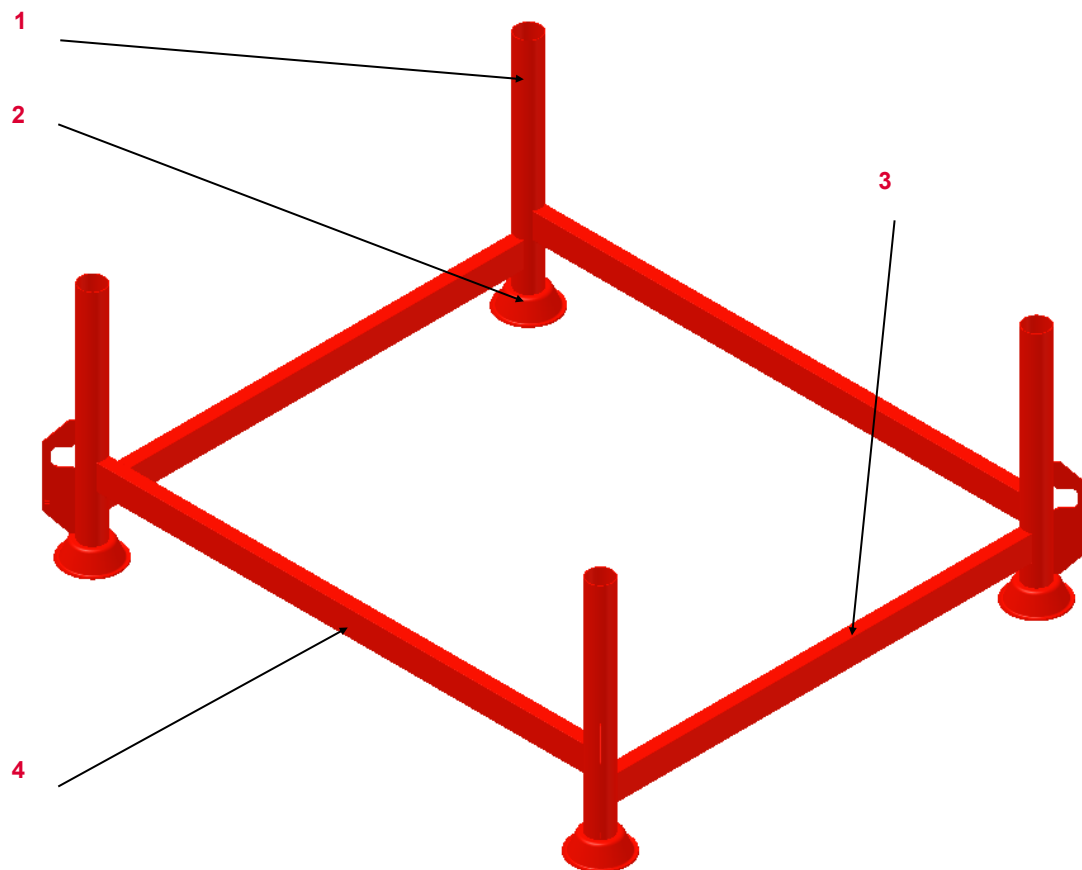

1	Stute
2	Fiksācijas stūris USP
3	Horizontālā caurule
4	Vertikālā caurule

Attiecināms uz	Artikula Nr.
Paletes RP 110x125 painted	106939
Paletes RP 80x110	111396

PERI kvalitātes prasības

Paletes un kraušanas ierīces



Paletes RP 110x125 RP 80x110	Apraksts	Darbība	Izmaksas	Tips
--------------------------------	----------	---------	----------	------

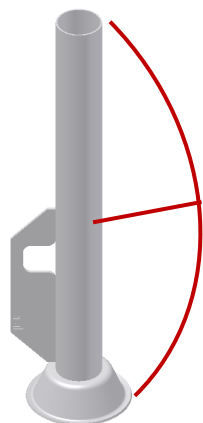

32.27 Stutes izliekums | bukte

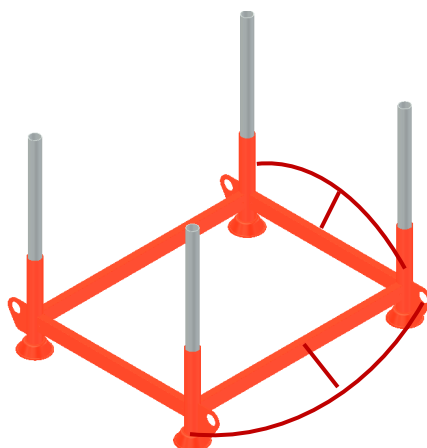

32.28 Horizontālās | Vertikālās caurules izliekums



PERI kvalitātes prasības

Paletes un kraušanas ierīces



Paletes SD 75 | 150 (126630 | 126582)

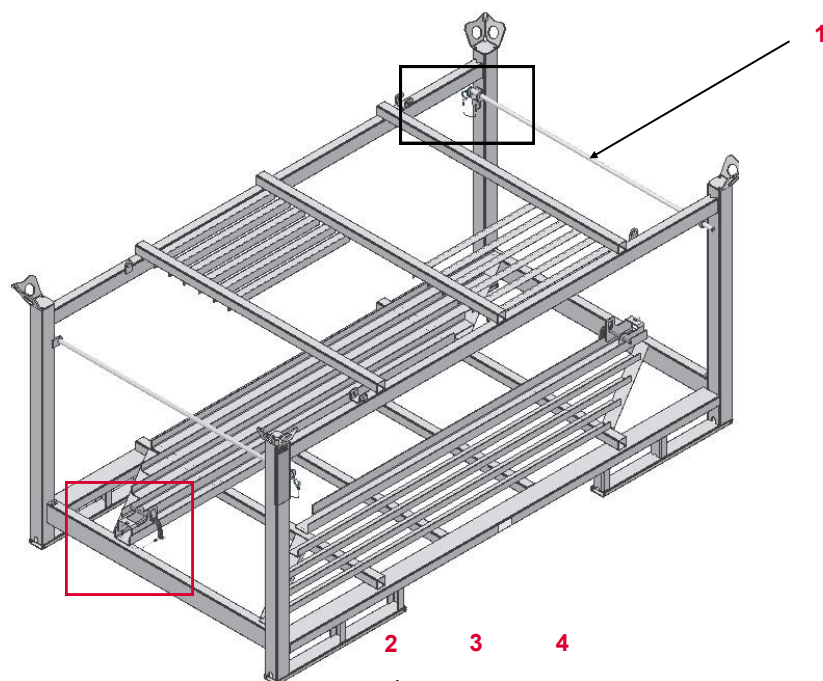

Nr.	Nosaukums	Artikula Nr.
1	Drošības spieķis	126618
2	Atspertapa	125699
3	Uzgalis	127302
4	Trosīte	127303
5	Bloķēšanas tapa	126638

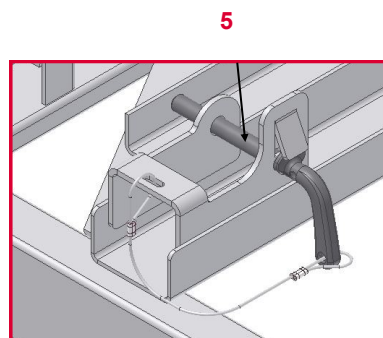
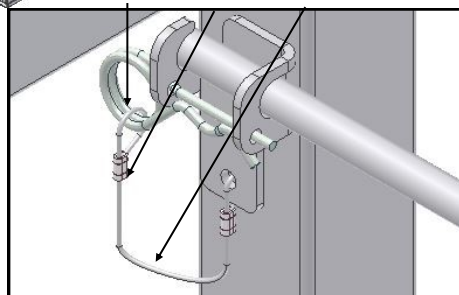

PERI kvalitātes prasības

Paletes un kraušanas ierīces



Paletes SD 150 I 75	Apraksts	Darbība	Izmaksas	Tips
---------------------	----------	---------	----------	------

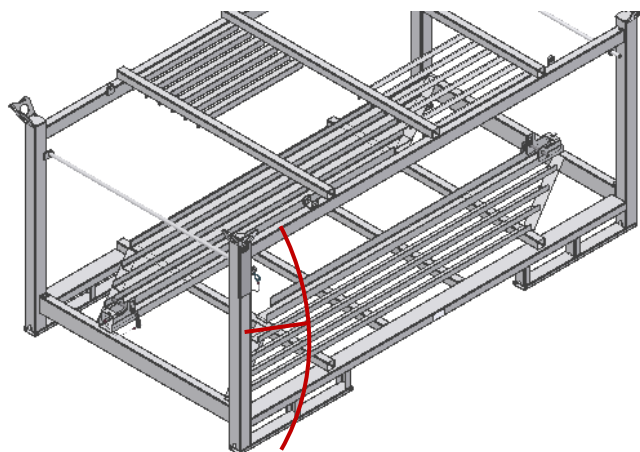

32.29 Stutes izliekums

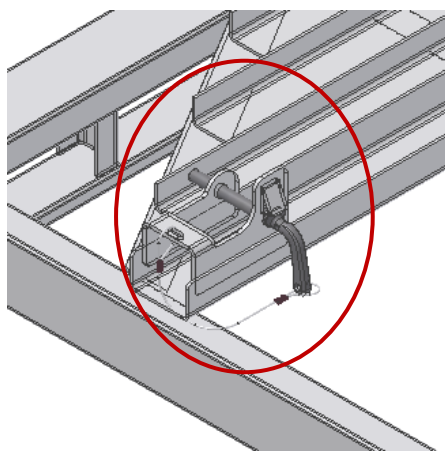

32.30 Bloķēšanas tapa pazudusi



126638



PERI kvalitātes prasības

Paletes un kraušanas ierīces



Palete EP 110 (123960)

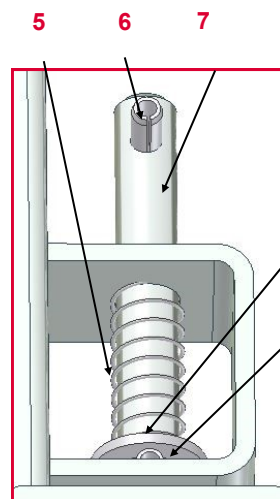
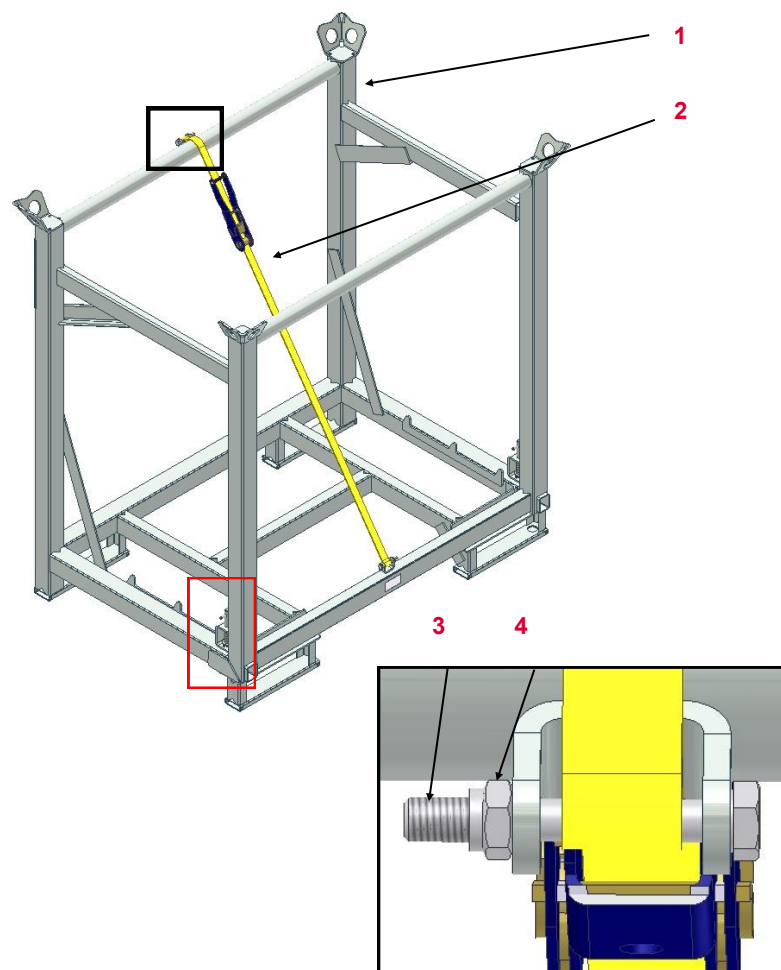

Nr.	Nosaukums	Artikula Nr.
1	Noņemamais paletes rāmis	123956
2	Strope 25 x 2550	117560
3	Skrūve M 8 x 60	710284
4	Uzgrieznis M 8	711071
5	Atspere	721816
6	Dībelis	725186
7	Tapa	123947
8	Paplāksne	711074
9	Dībelis	780807

PERI kvalitātes prasības

Paletes un kraušanas ierīces



Paletes EP 110	Apraksts	Darbība	Izmaksas	Tips
----------------	----------	---------	----------	------



32.31 Pacelšanas atvere nolocīta

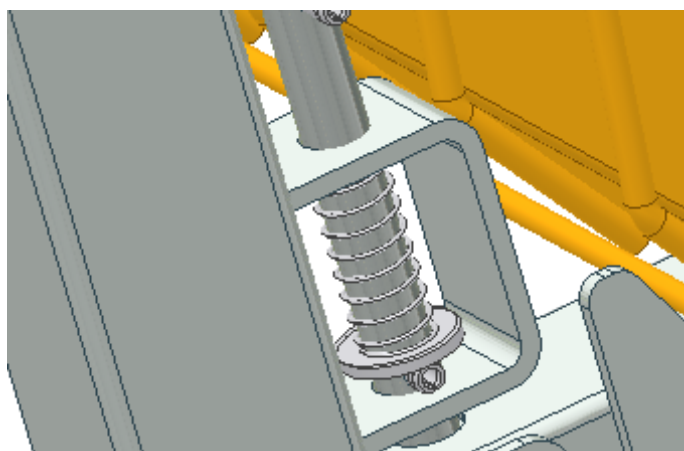

32.32 Tapa

- Pazudusi
- Vai pietrūkst detaļas



PERI kvalitātes prasības

Paletes un kraušanas ierīces



Paletes EP 110	Apraksts	Darbība	Izmaksas	Tips	
	32.33 Strope		117560		
	<ul style="list-style-type: none"> ■ Pazudusi 		117560		
	<ul style="list-style-type: none"> ■ Vai marķējums nesalasāms 		117560		

PERI kvalitātes prasības

Paletes un kraušanas ierīces



Rāmju palete USP 72 | 104 (100660 | 100678)

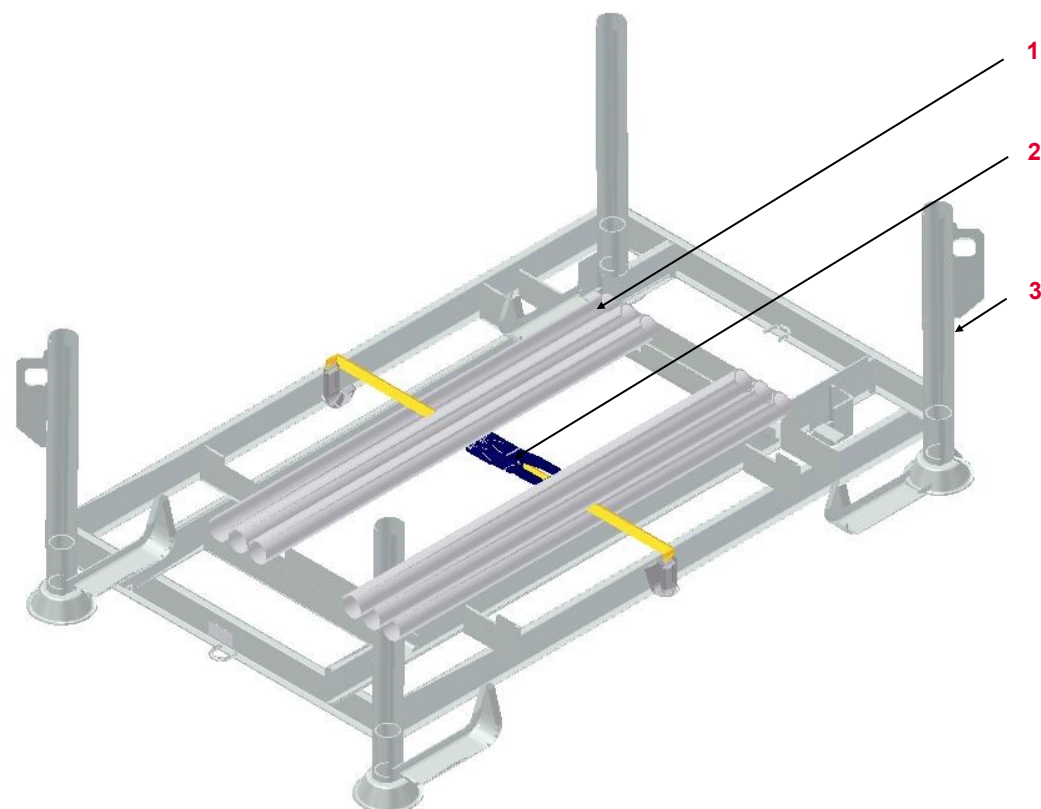









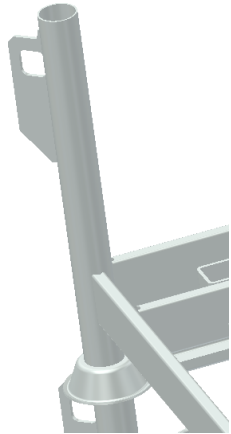





Nr.	Nosaukums	Artikula Nr.
1	Caurules	100706
2	Strope	100707
3	Stute	

PERI kvalitātes prasības

Paletes un kraušanas ierīces



Rāmju palete USP 72 / 104	Apraksts	Darbība	Izmaksas	Tips
	32.34 Stute salocīta <ul style="list-style-type: none"> ■ Izliekums > 1 ° 	 		
	32.35 Strope <ul style="list-style-type: none"> ■ Mehāniskais bojājums (piem. iegriezums) ■ Vai pazudusi ■ Vai izdilusi 	 100707  100707  100707	  	  

PERI kvalitātes prasības

Paletes un kraušanas ierīces



Rāmju palete USP 72 / 104	Apraksts	Darbība	Izmaksas	Tips
---------------------------	----------	---------	----------	------

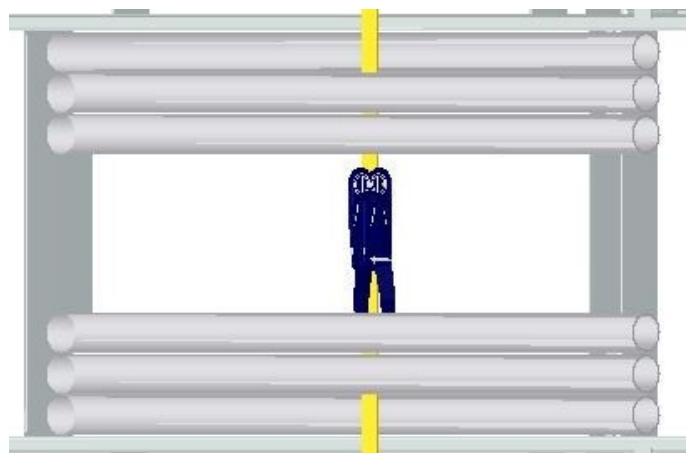

32.36 Caurule

- Pazudusi
- Vai mehāniski bojāta



100706



100706



32.37 Iespiedums | bukte rāmī

















- ≤ 5 mm dziļumā
- Vai t > 5 mm
- Vai bukte (piem. no autopacelāja ragiem)



PERI kvalitātes prasības

Vārdnīca



Ikona	Nozīme	Ikona	Nozīme	Ikona	Nozīme
	Nav derīgs - materiāls jānoraksta		Jāizraksta rēķins (klientam)		Vizuāls bojājums
	Derīgs - materiāls paliek nomas parkā		Rēķins nav jāizraksta		Funkcionāls bojājums
	Norakstāms materiāls – izdošana nomā nav pieļaujama dēļ neatbilstības drošības prasībām		Saīsināt materiālu		Funkcionāls bojājums - izdošana nomā nav pieļaujama
	Remonts saskaņā ar instrukciju		Marķēt materiālu		Statisks bojājums - izdošana nomā nav pieļaujama
	Aukstā labošana – veicot metinājuma šuvju un blakus detaļu pēcpārbaudi		Nomainīt bojāto materiālu		
	Remonts tikai pēc izmaksu tāmes izvērtēšanas		Atvietot trūkstošo materiālu		
	Materiāla tīrīšana				